



12 Aspirator de mână



Piese



Bloc N 3x11 (4)



Bloc N 3x7 (3)



Bloc N 2x11 (4)



Bloc N 2x7 (1)



Bloc N 2x9 (2)



Bloc N 3x9 (3)



Bloc N 1x7 (2)



Bloc N 1x5 (2)



Nit dublu de tip I (1)

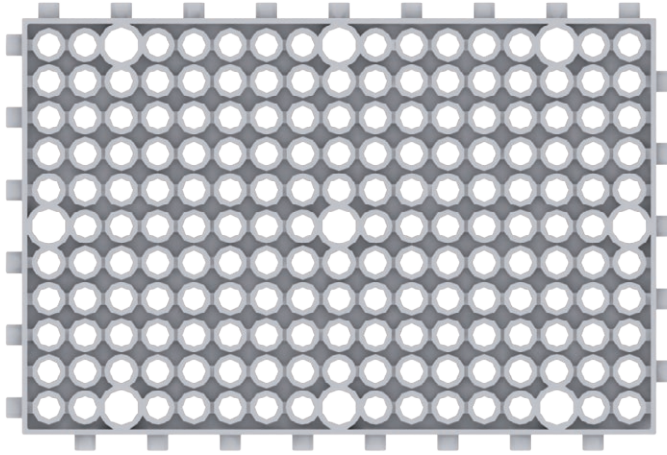

Bloc 11x17 (1)



Adaptor L 3x3 (4)

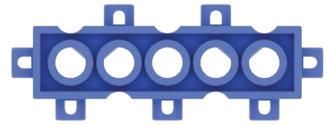

Bloc 1x5 (4)

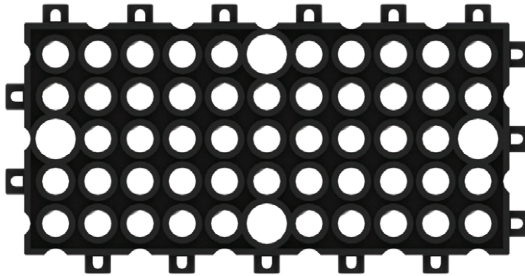

Bloc 5x11 (4)



Piuliță (2)



Adaptor L (2)



Nit clasic (8)

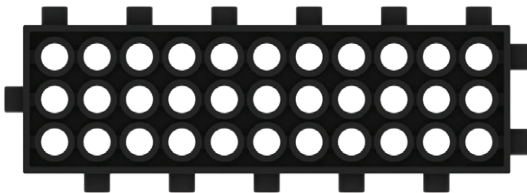

Bloc 3x11 (4)



Nit S (24)



Nit L (4)

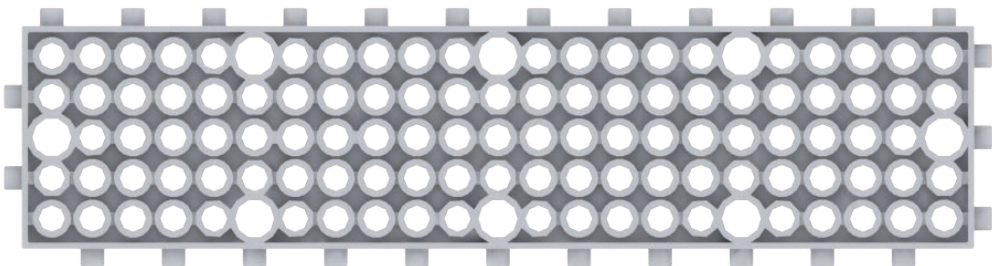

Bloc 5x23 (2)

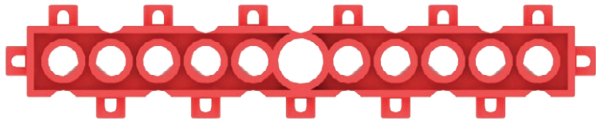

Bloc 1x11 (4)

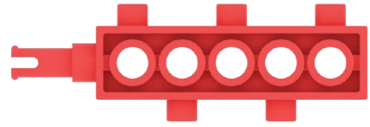

Bloc cu ax (2)

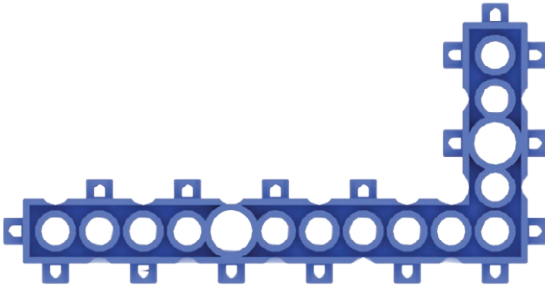

Bloc de 90° (1)



Motor 1 (2)



Bloc de îmbinare 2 (4)



Jantă/Hub 1 (2)



Roată/Wheel 1 (2)



Roată S (2)



Jantă/Hub 2 (2)



Acumulator 1 (1)

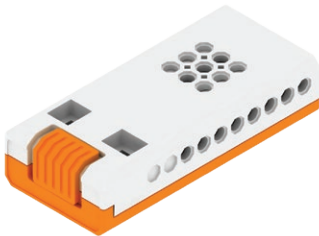

Acumulator 2 (1)



Cablu de conectare (2)

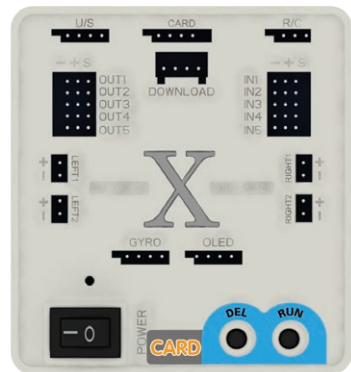

Placă de comandă (1)

01

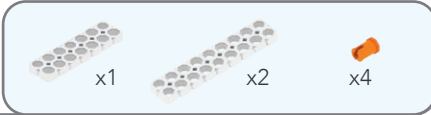
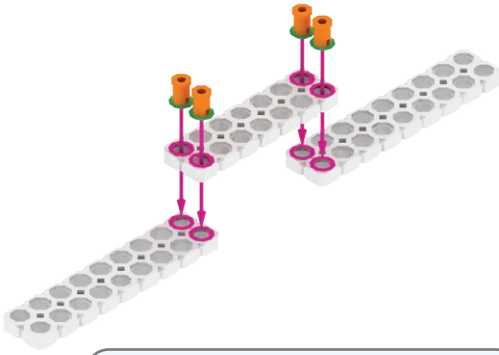

02

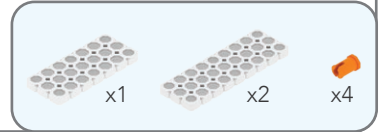
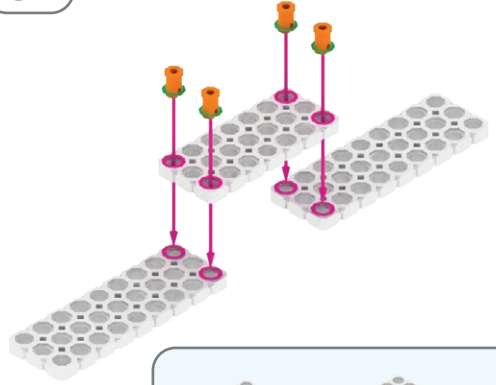

03

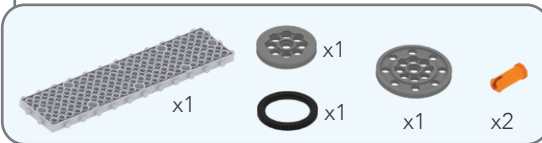
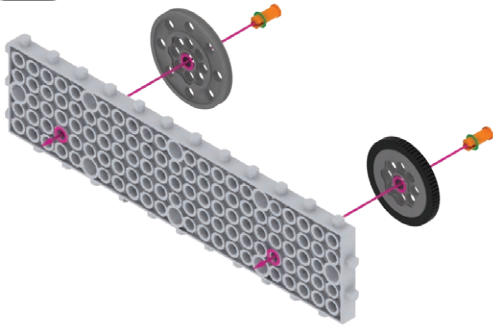

04

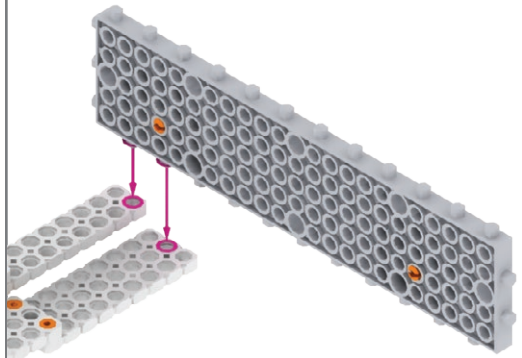

05

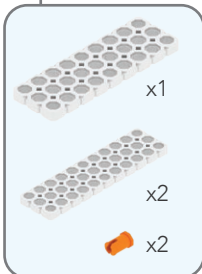
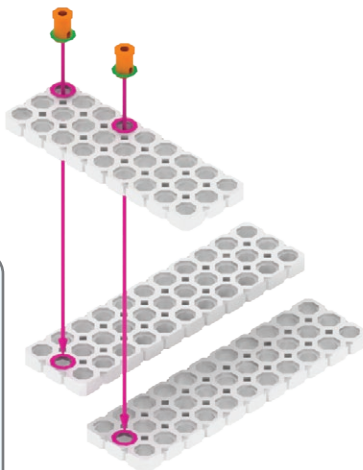

06

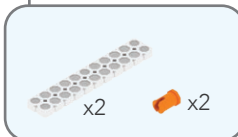
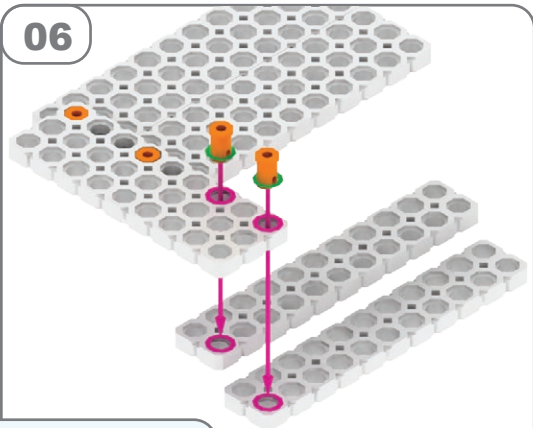

07

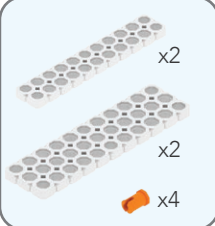
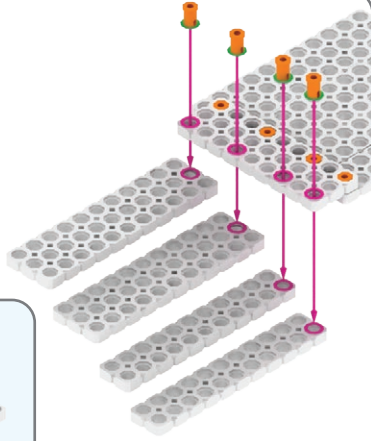

08

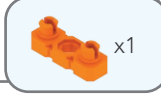
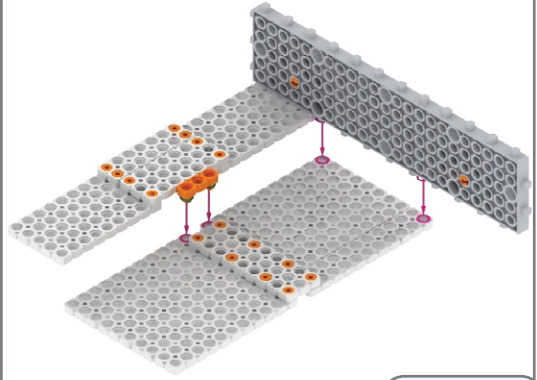

09

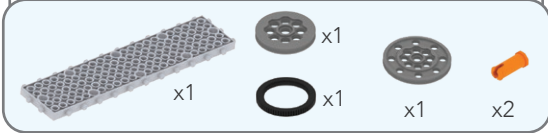
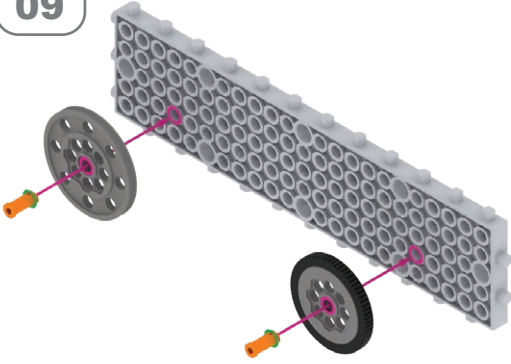

10

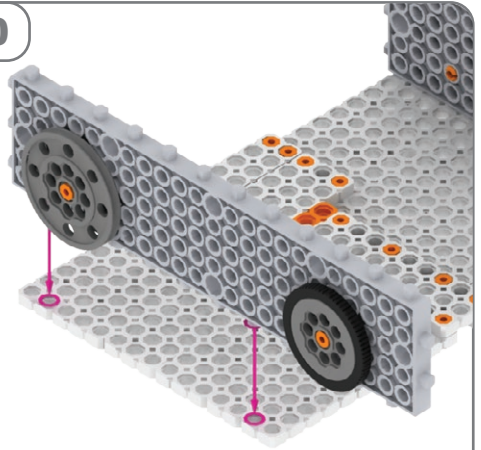

11

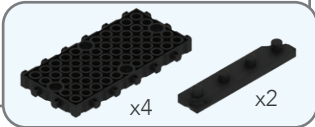
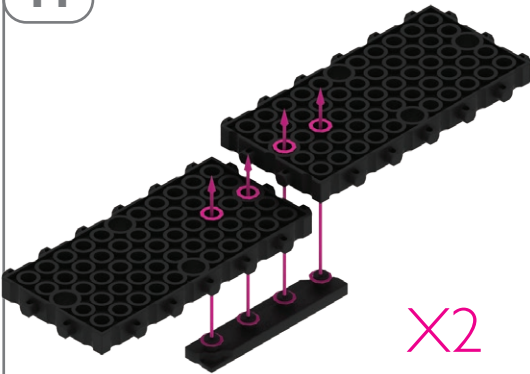

12

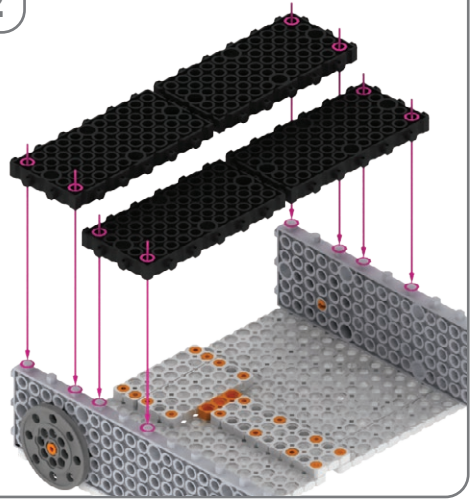

13

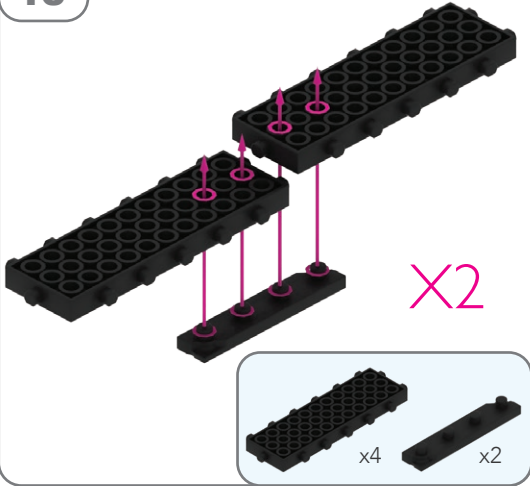

14

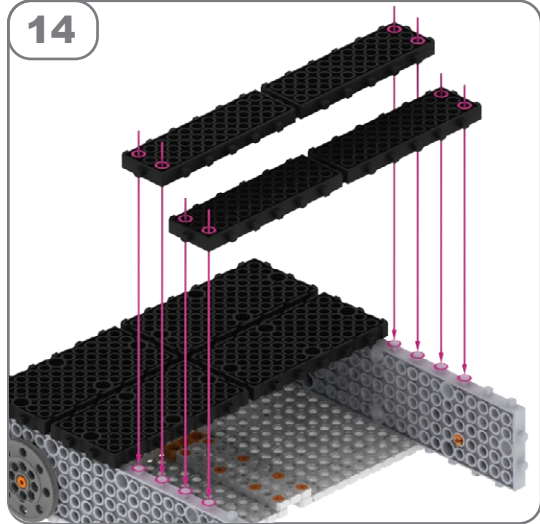

15

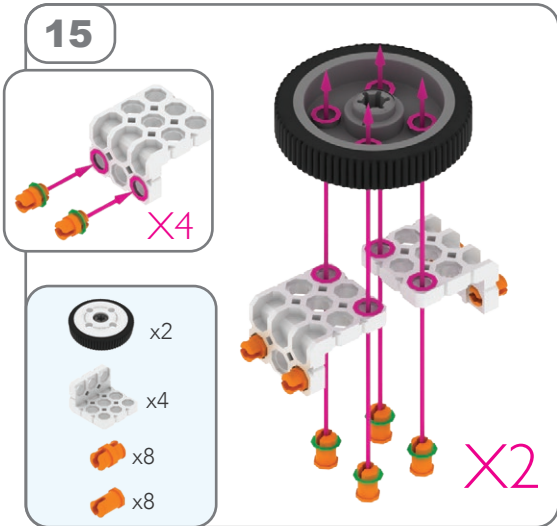

16

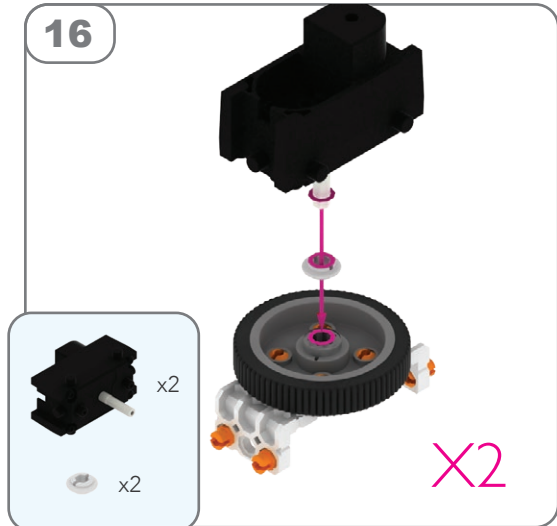

17

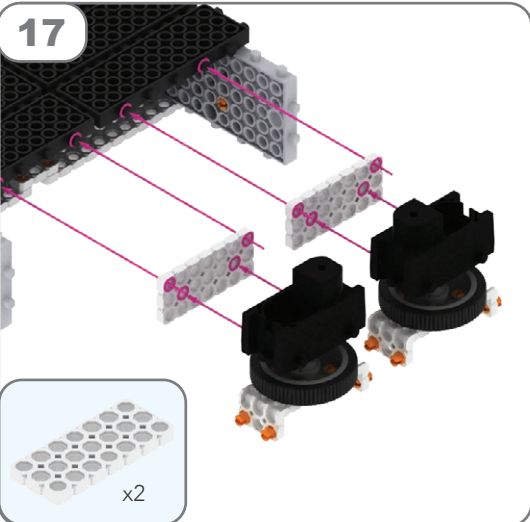

18

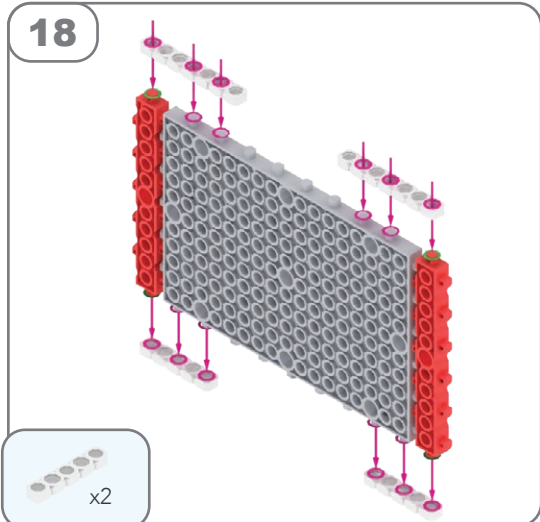

Notă: Acest triunghi roșu ▲ marchează poziția

19

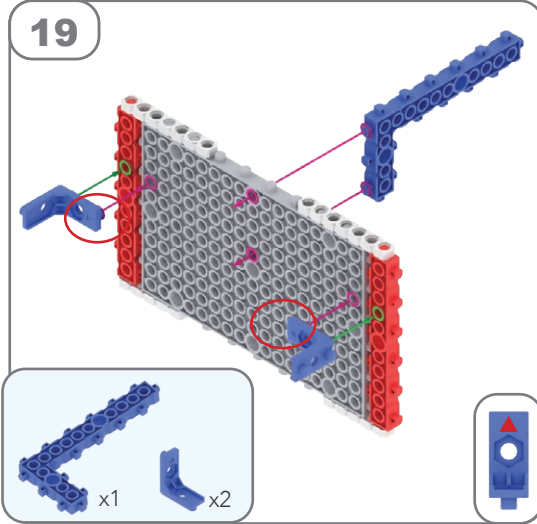

20

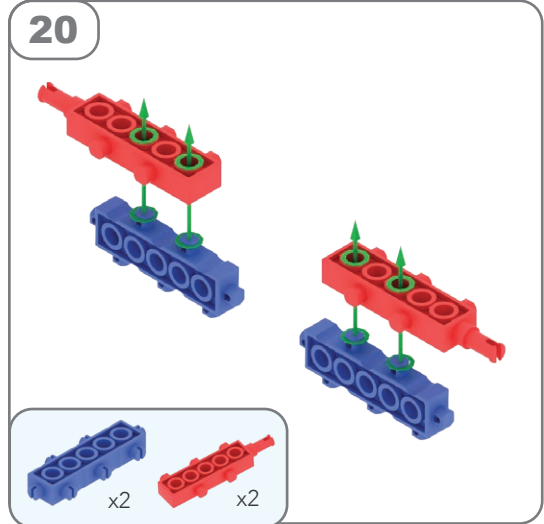

21

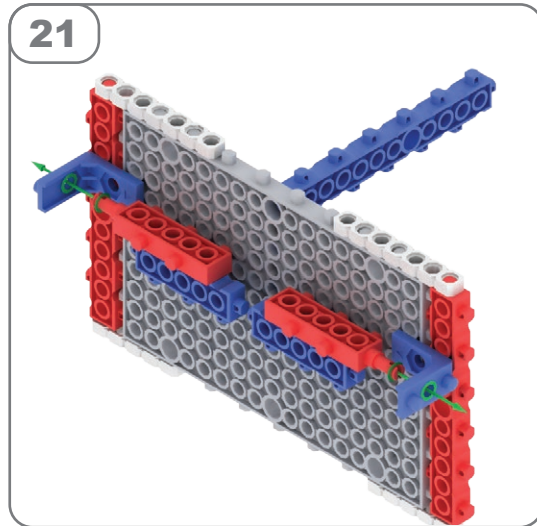

22

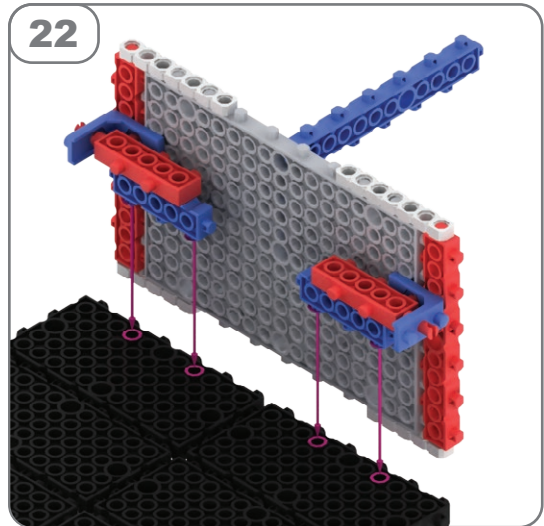

23

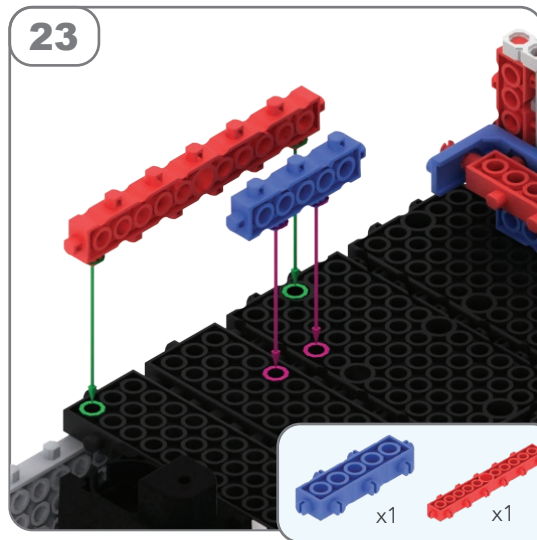

24

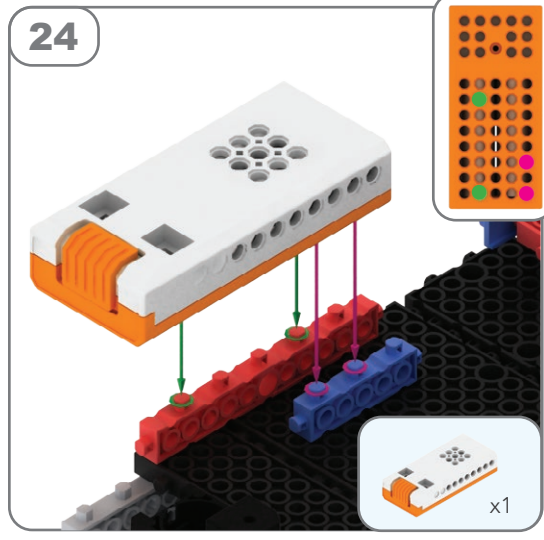

25

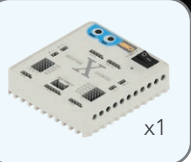
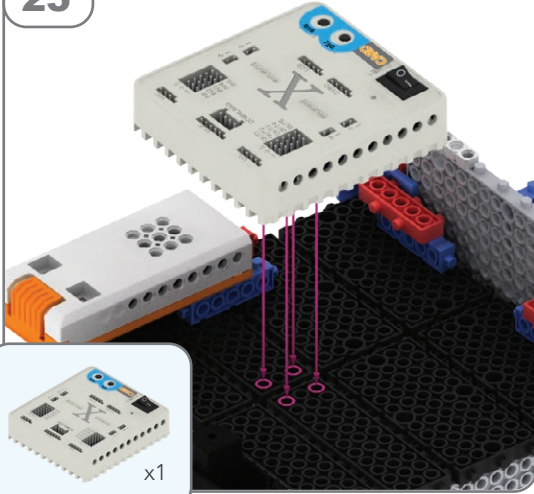

26

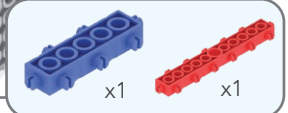
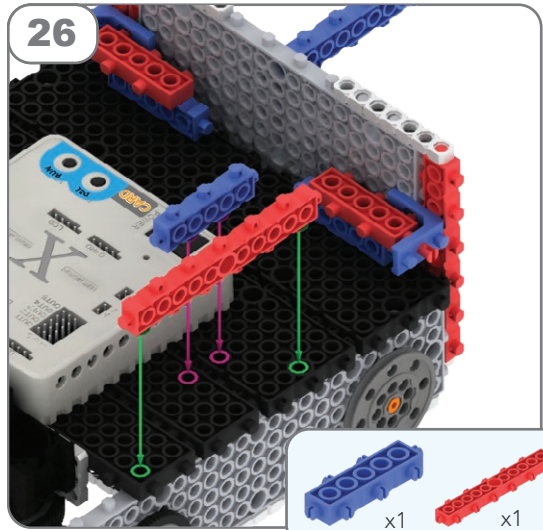

27

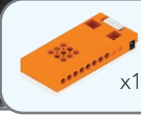
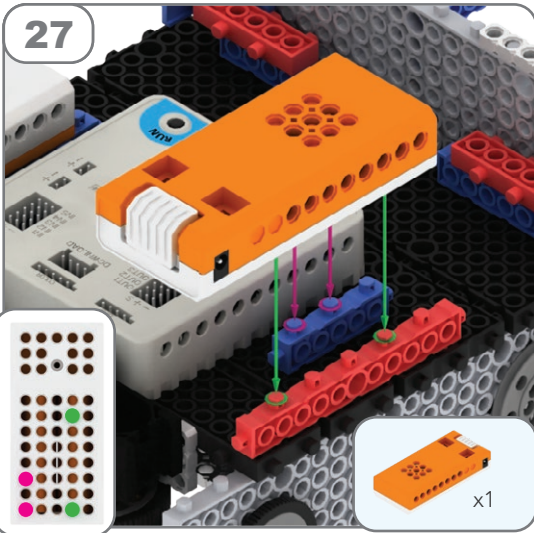

OK

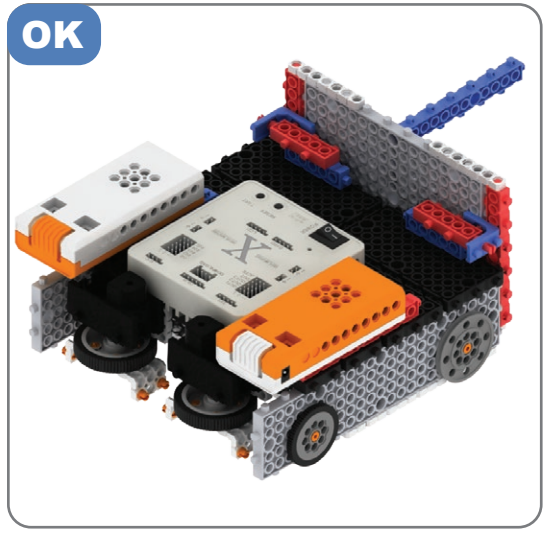

Cum se conectează?

- 1 Conectează cele două motoare la placă, după cum ți se arată în continuare.

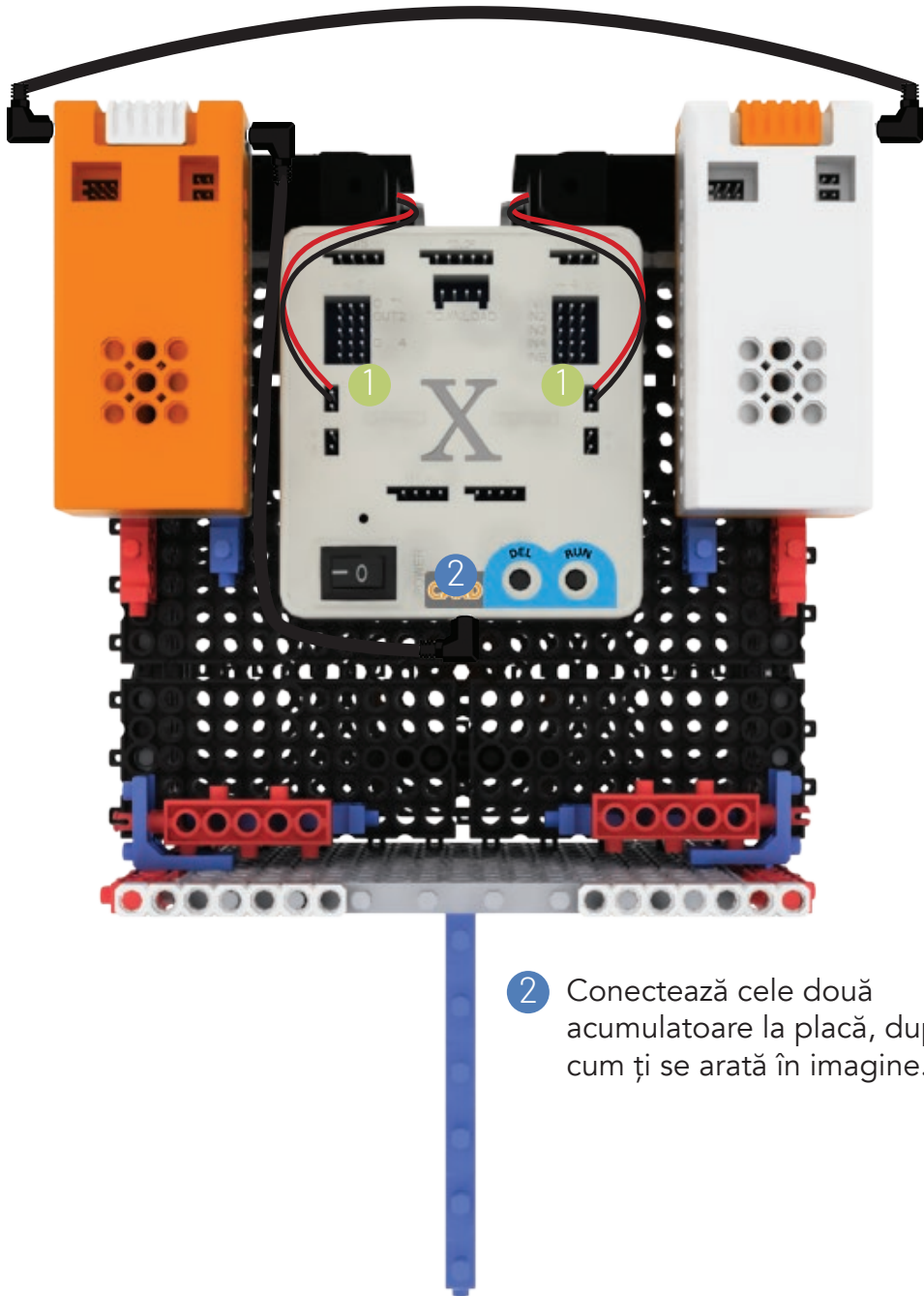

- 2 Conectează cele două acumulatori la placă, după cum ți se arată în imagine.

Acumulatorii vor furniza energie atunci când sunt conectate la placă prin cablul de conectare negru, indiferent de poziția întrerupătoarelor.

În practică

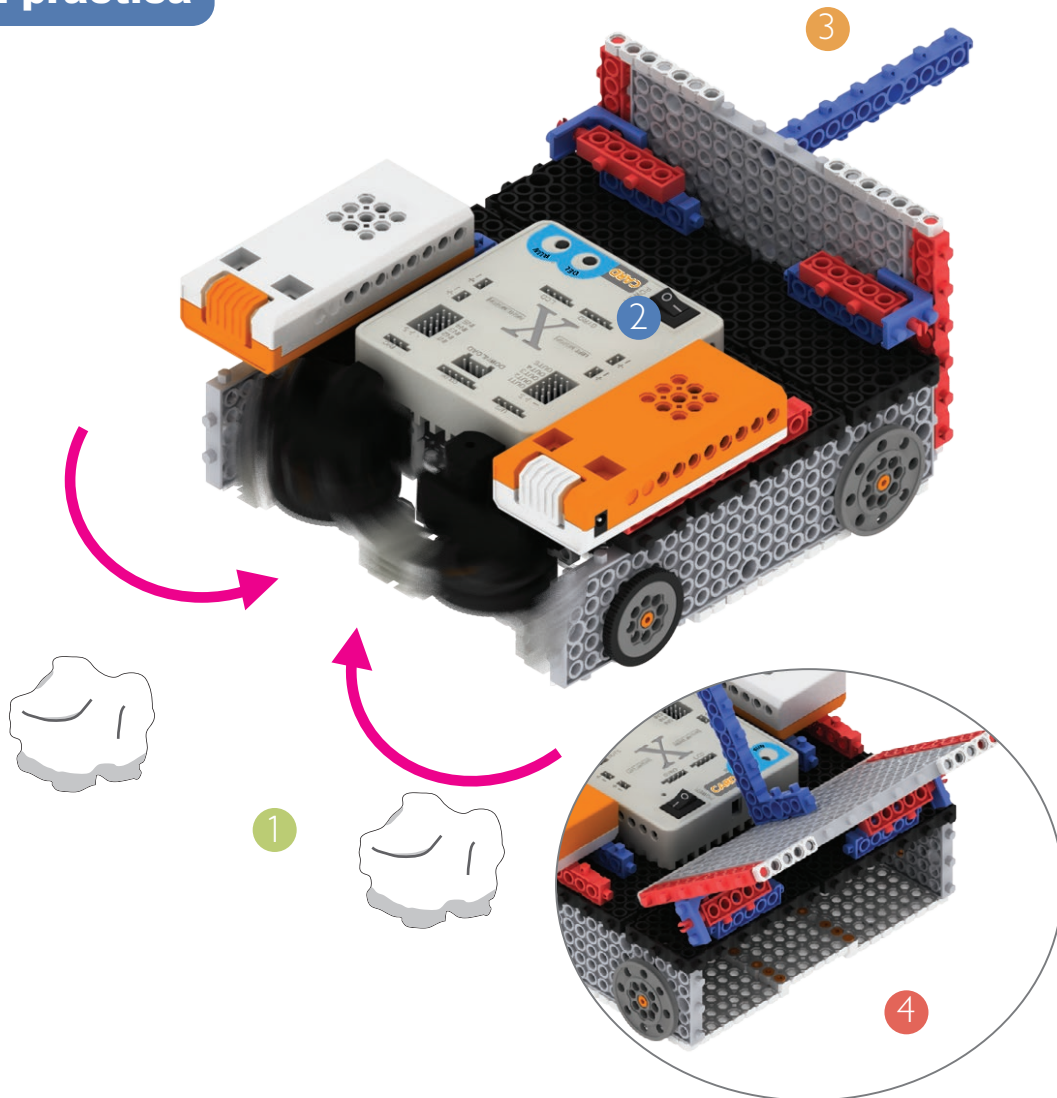

- 1 Fă o biluța de hârtie, caută să nu fie prea grea!
- 2 Apasă butonul POWER, apoi RUN pentru a selecta modul 1 de funcționare a motorului. Apasă din nou RUN: motorul din stânga se va învârti într-un sens și motorul din dreapta în celălalt.
- 3 Ține robotul de blocul albastru și adu-l mai aproape de biluța de hârtie pentru a-l aspira.
- 4 Ridică apoi capacul din spate pentru a scoate biluța de hârtie.