

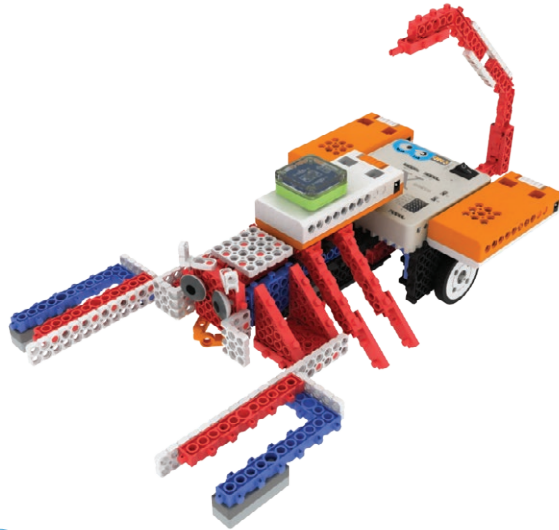

17 Scorpion

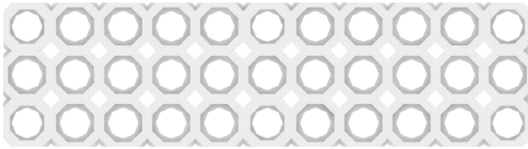

Piese



Bloc N 3x11 (1)



Piesă de unghi B (1)



Bloc N 2x13 (2)



Piesă de unghi A (1)



Bloc N 3x5 (1)



Bloc N 2x5 (3)



Bloc N 2x7 (2)



Bloc N 1x7 (1)



Bloc N 1x11 (1)

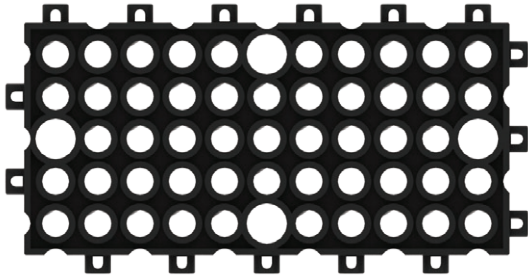

Bloc 5x11 (2)

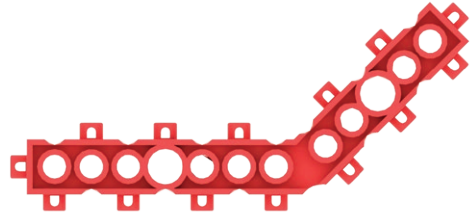

Bloc de 135° (6)

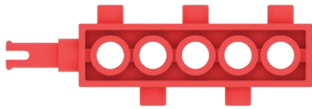

Bloc cu ax (3)



Adaptor L 3x4 (2)



Adaptor L 1x3 (2)



Bloc oval (2)

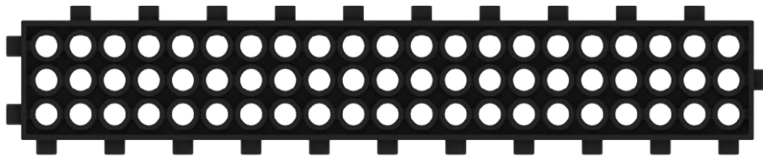

Bloc 3x21 (1)

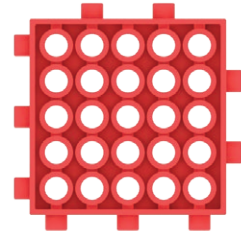

Bloc 5x5 (3)

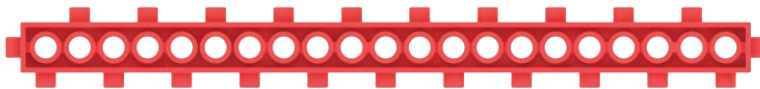

Bloc 1x21 (1)

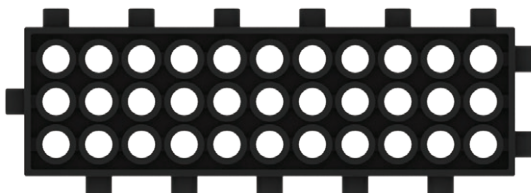

Bloc 3x11 (2)

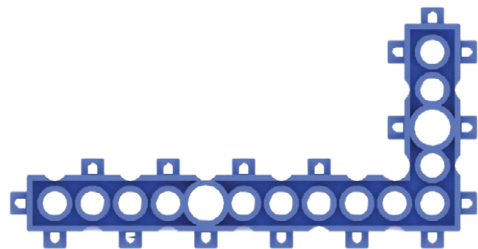

Bloc de 90° (2)



Bloc de îmbinare 1 (6)



Bloc de îmbinare 2 (1)



Nit clasic (6)



S-shaft Ax S (1)



Piuliță (2)



Cauciuc roșu de ax/
 Red bush (2)



Senzor cu infraroșu (2)

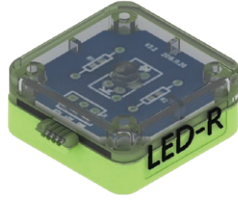

LED R (1)

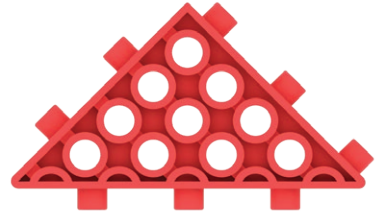

Bloc triunghiular (4)



Roată S (2)



Jantă/Hub I (2)

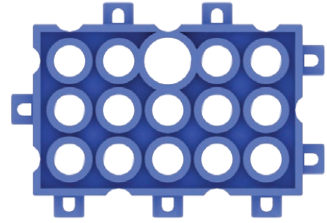

Bloc 3x5 (2)

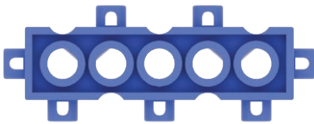

Bloc 1x5 (2)



Adaptor L (4)



Motor 2 (2)

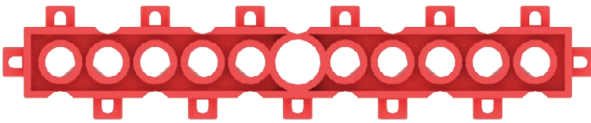

Bloc 1x11 (3)



Cablu de conectare (3)

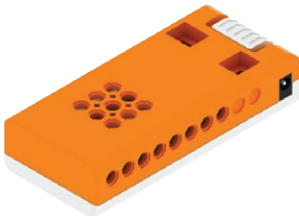

Acumulator 1 (2)

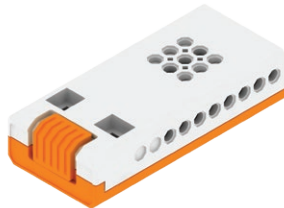

Acumulator 2 (1)

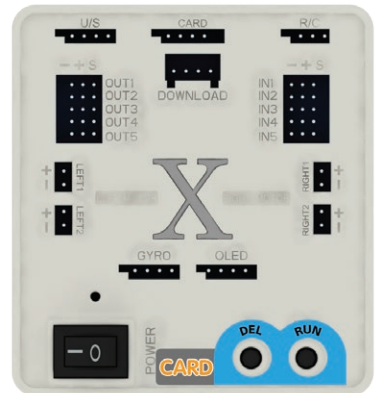

Placă de bază (1)

01

1:1

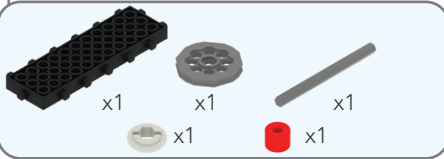
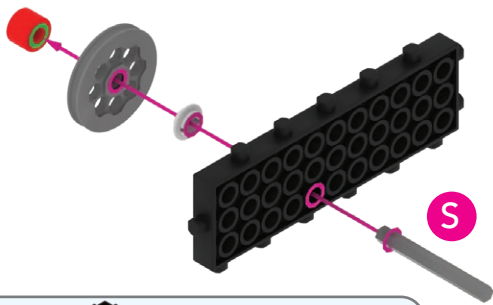

02

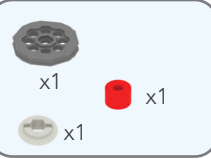
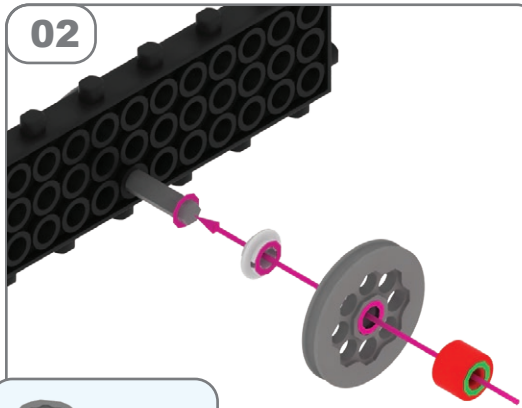

03

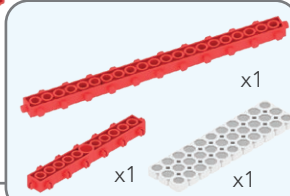
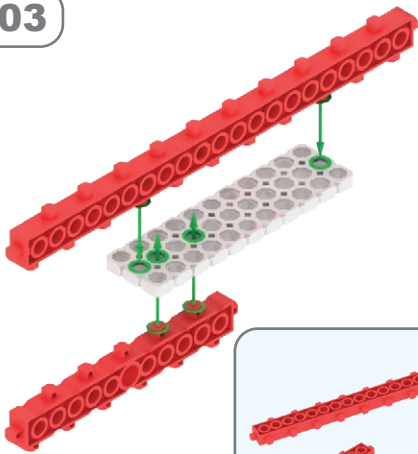

04

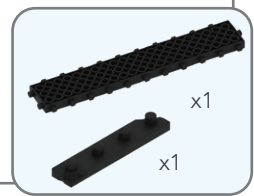
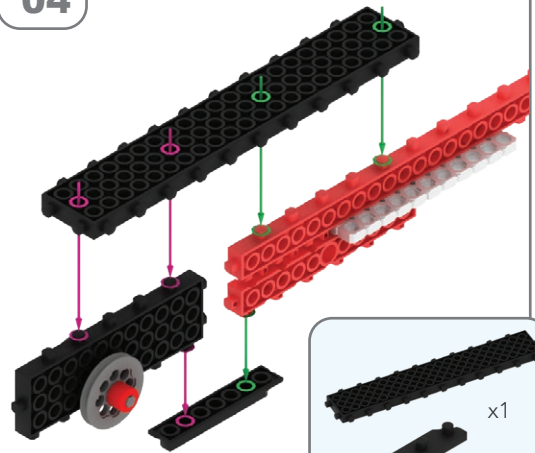

05

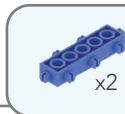
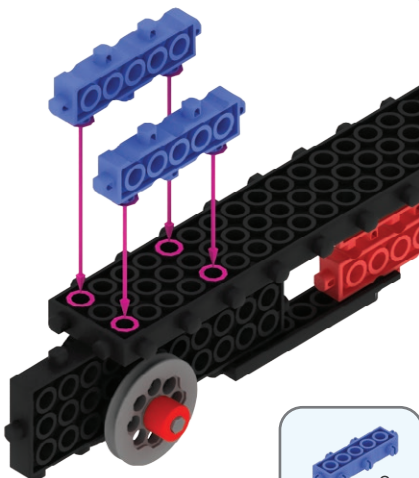

06

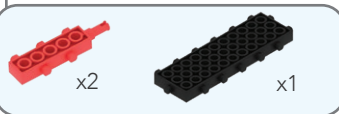
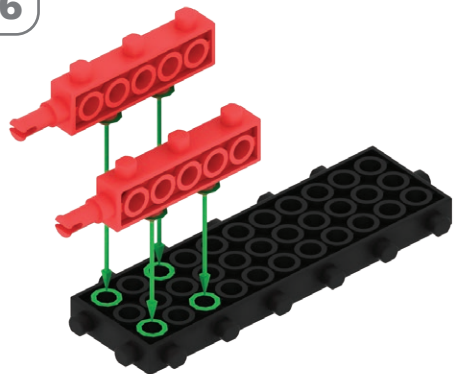

07

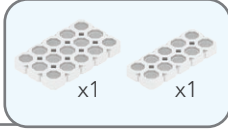
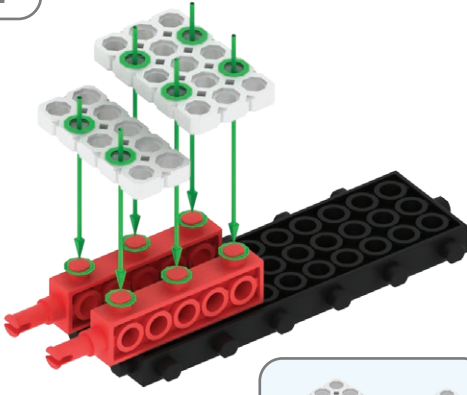

08

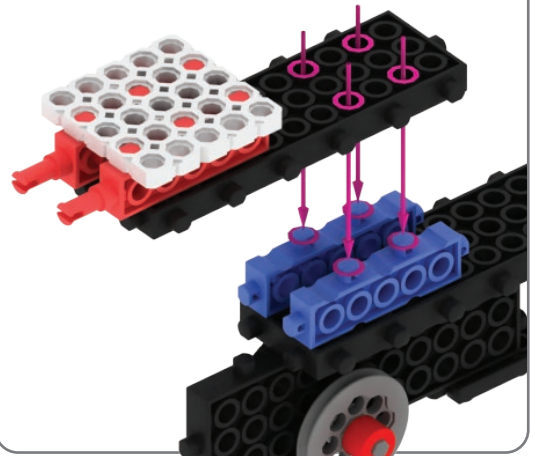

09

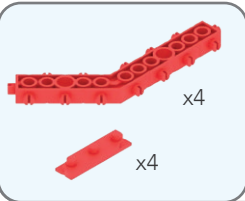
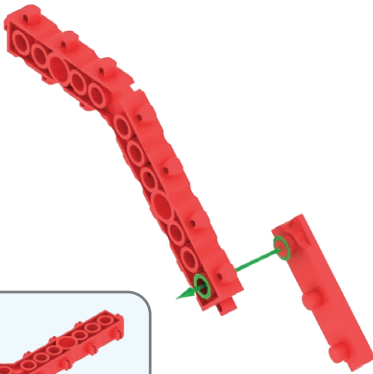

x4

10

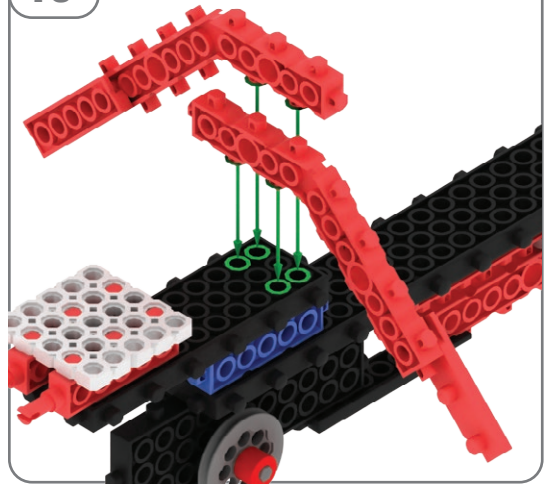

11

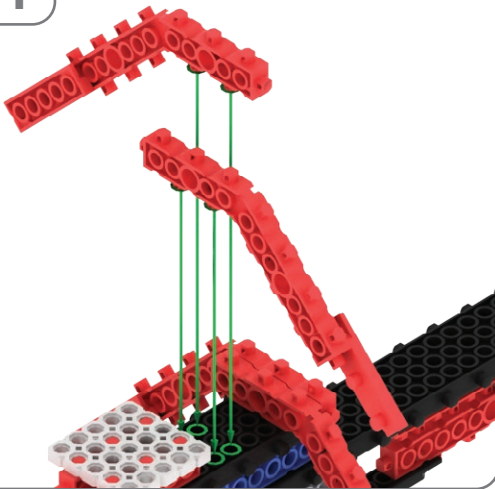

12

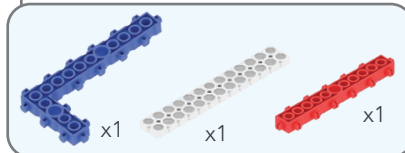
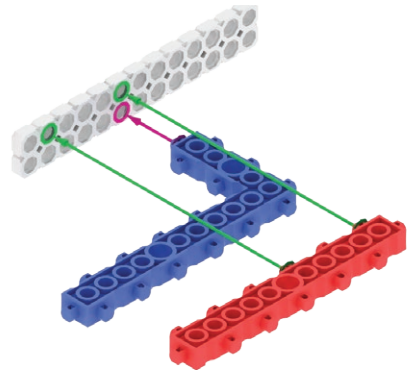

13

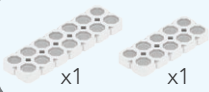
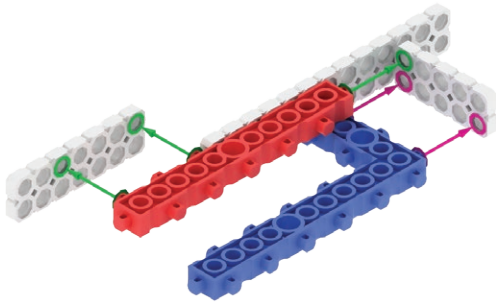

14

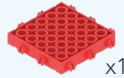
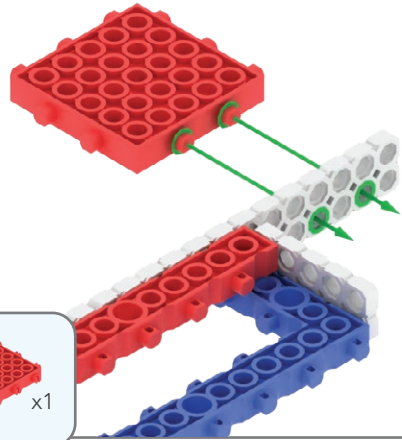

15

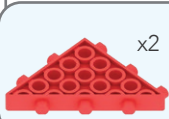
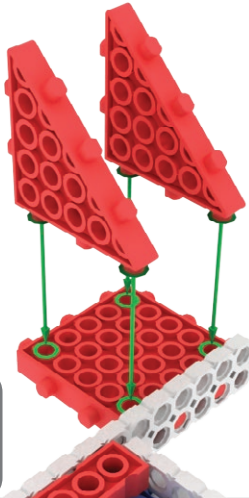

16

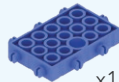
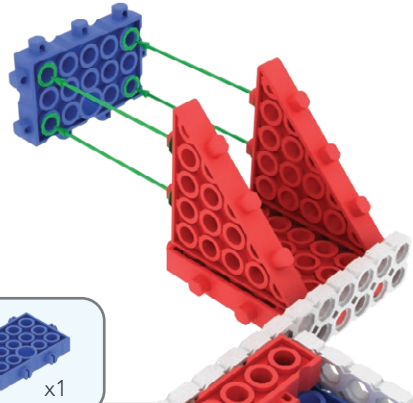

17

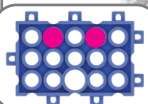
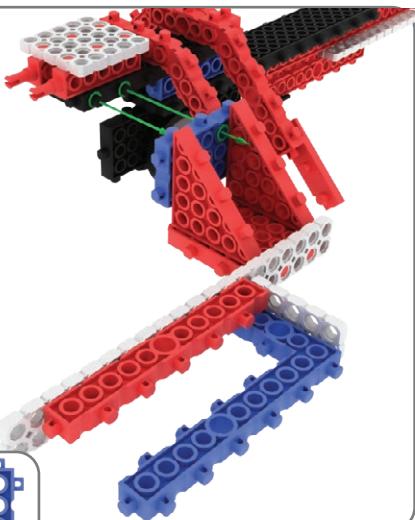

18

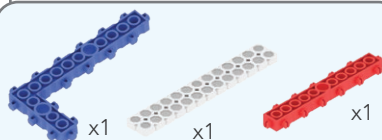
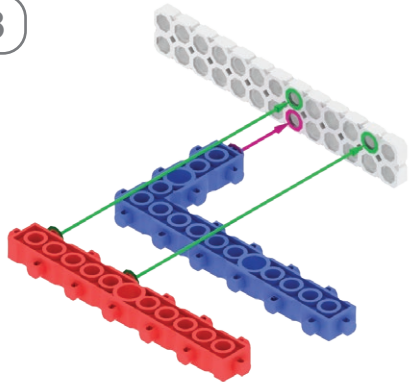

19

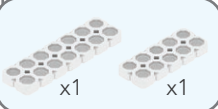
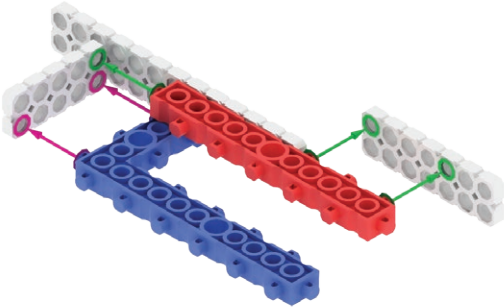

20

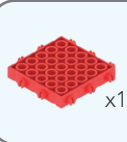
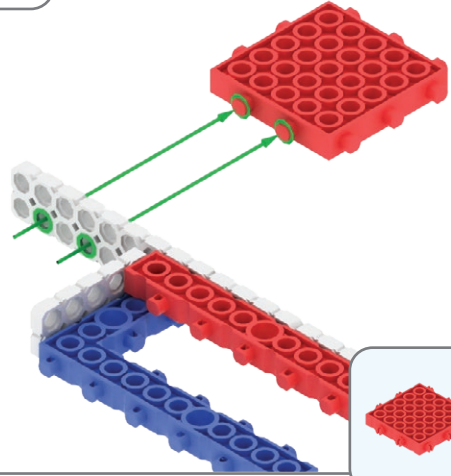

21

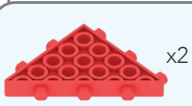
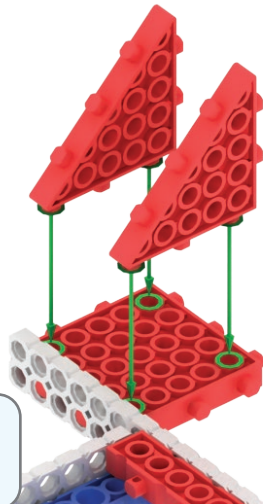

22

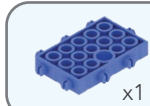
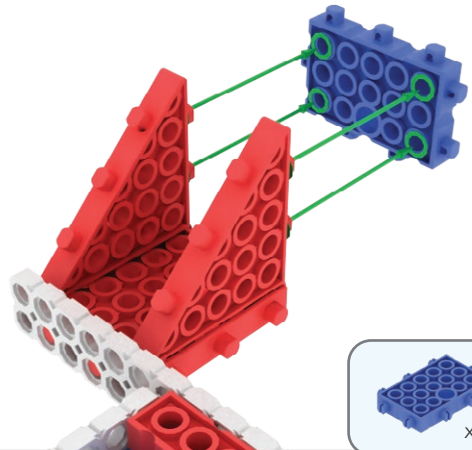

23

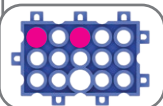
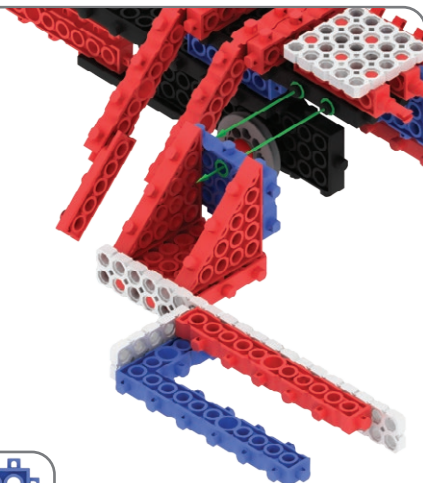

24

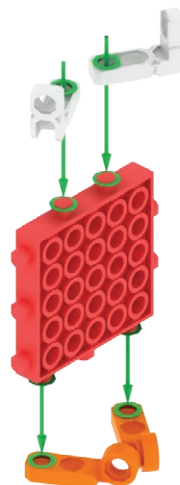

25

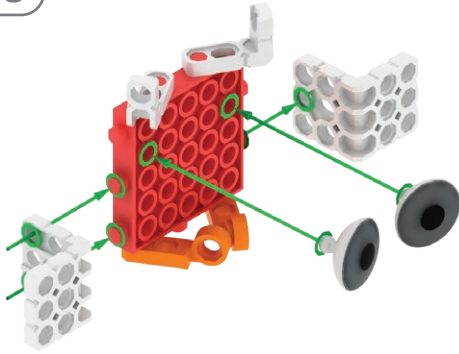

26

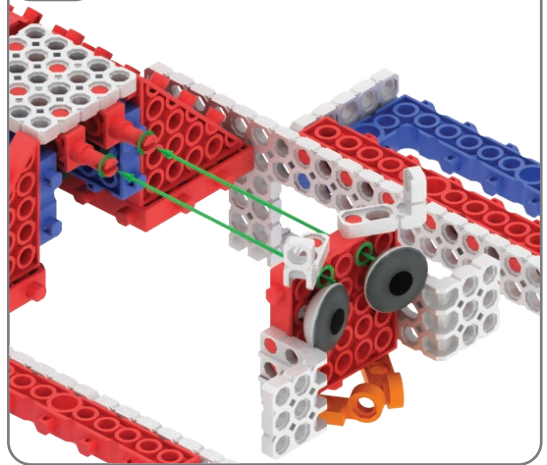

27

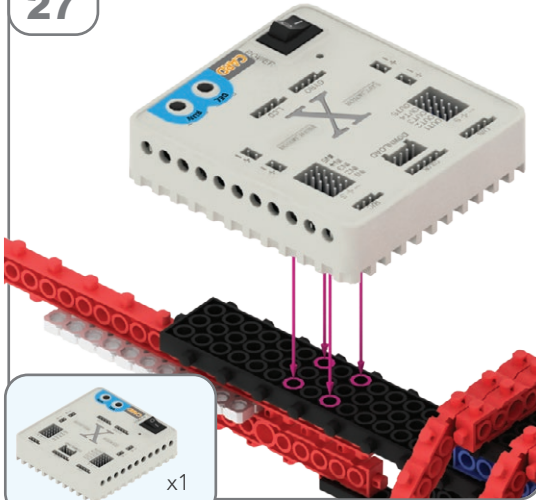

28

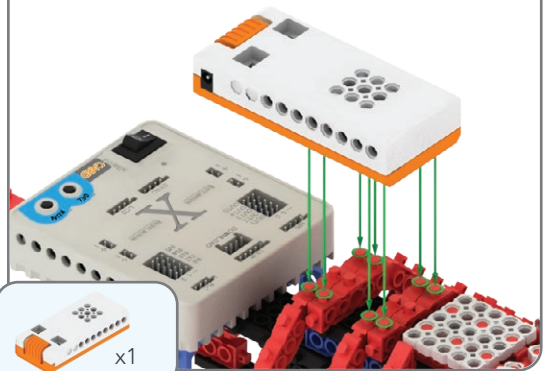
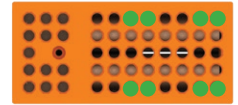

29

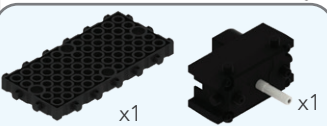
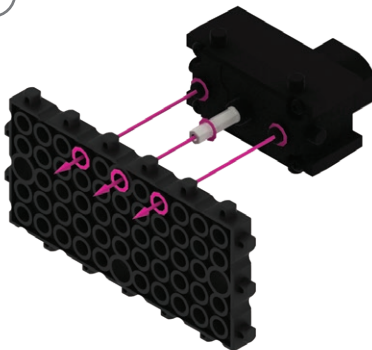

30

Notă: Triunghiul roșu ▲ indică poziția.

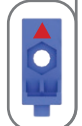
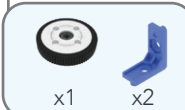
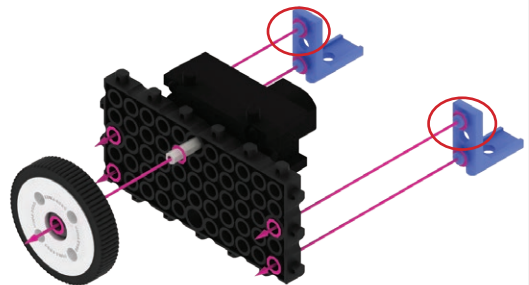

Notă: Triunghiul roșu ▲ indică poziția.

31

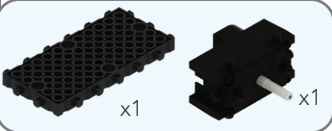
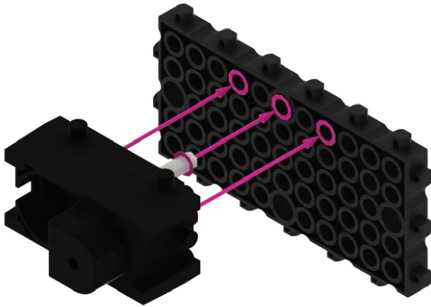

32

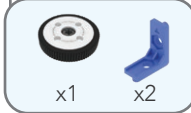
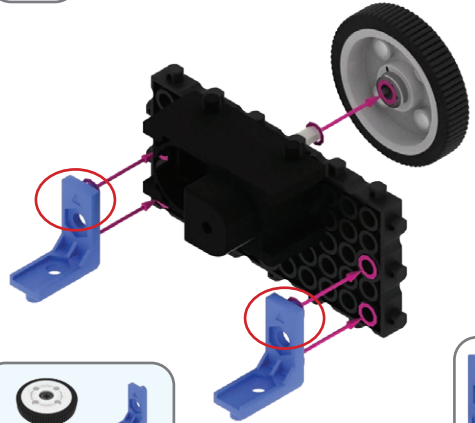

33

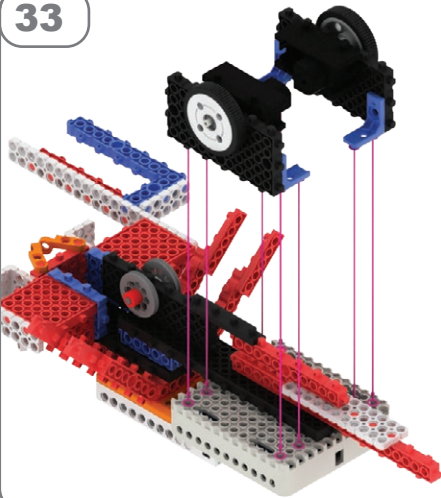

34

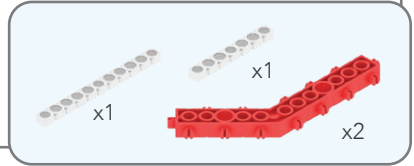
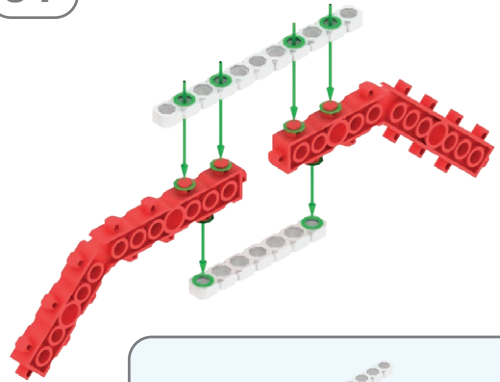

35

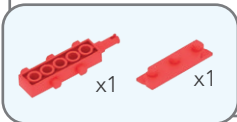
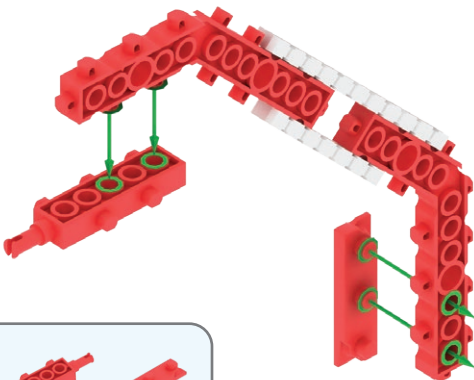

36

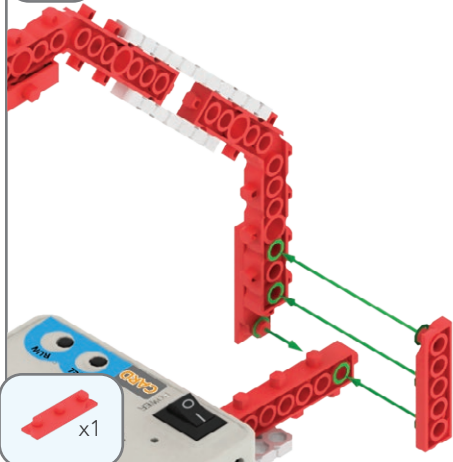

37

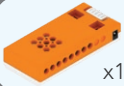
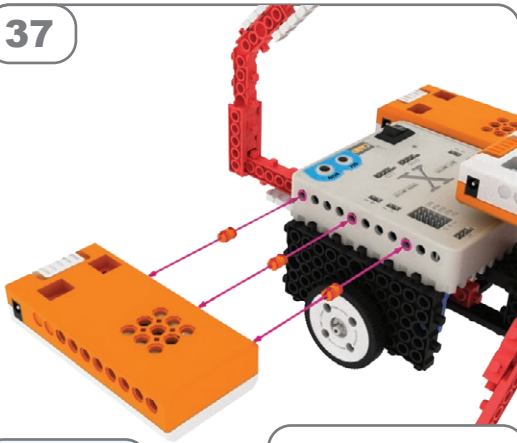

38

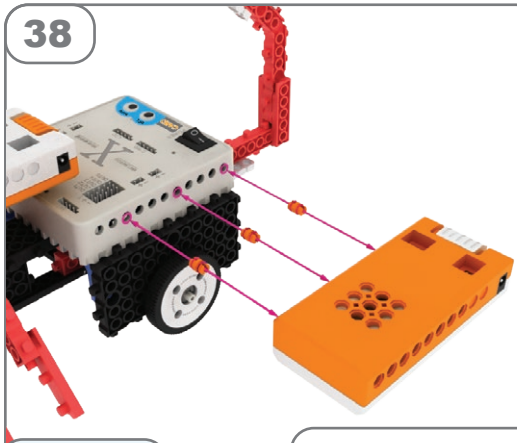

39

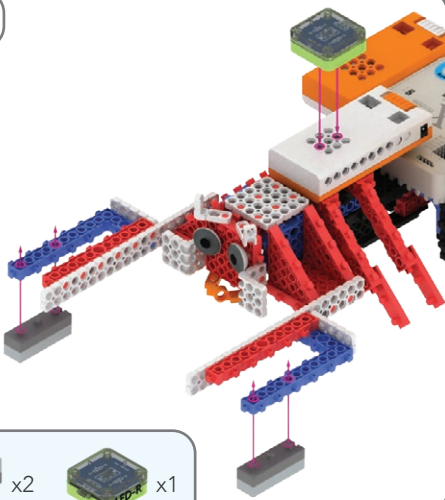

OK

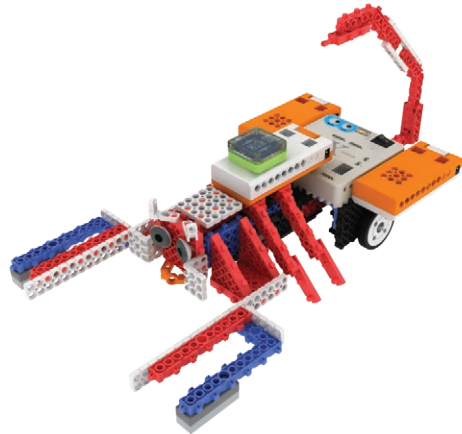

Cum se conectează?

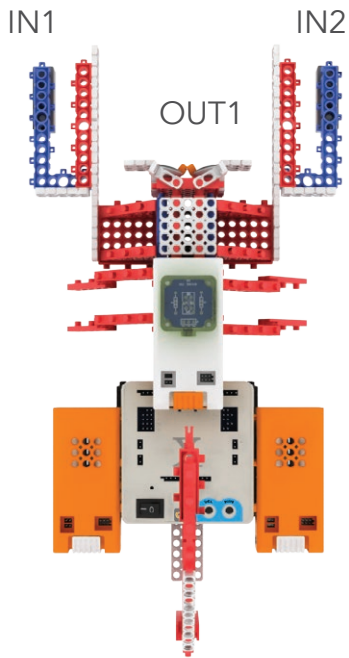

- 1 După cum vezi în imagine, te rugăm să conectezi senzorul infraroșu din stânga la portul IN1 și pe cel din dreapta la portul IN2.
- 2 Conectează ledul R la portul OUT1.
- 3 Conectează cele două motoare la placa de bază.
- 4 Conectează acumulatorii la placa de bază.

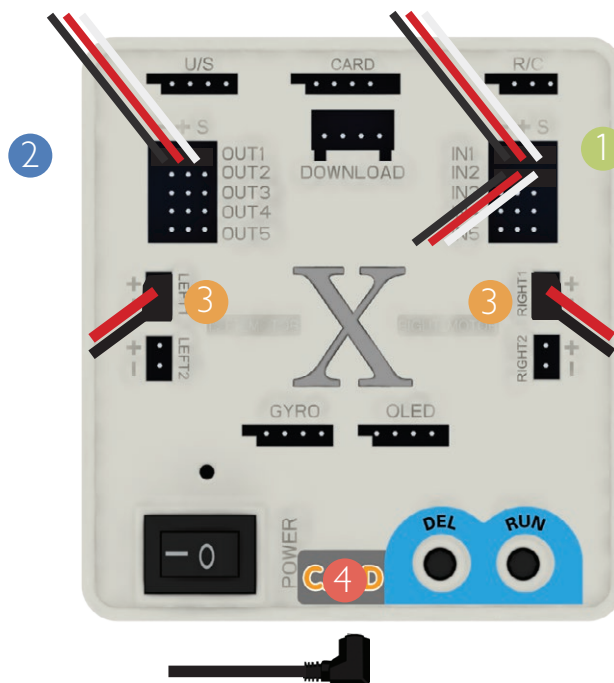

Acumulatorii vor furniza energie când sunt conectați la placă prin cablul negru, indiferent de poziția întrerupătoarelor.

În practică

Pornește placa, apoi apasă butonul RUN și apoi butonul DEL de patru ori. X se va face violet și va pâlpoi, apoi apasă RUN pentru a activa modul preprogramat 5.

Robotul începe să se miște!

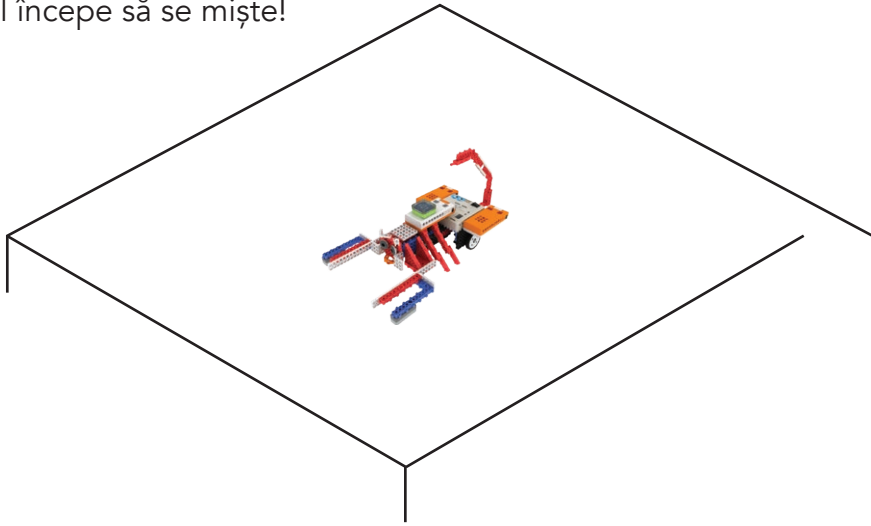

Când un senzor cu infraroșu detectează marginea, robotul se întoarce.

