

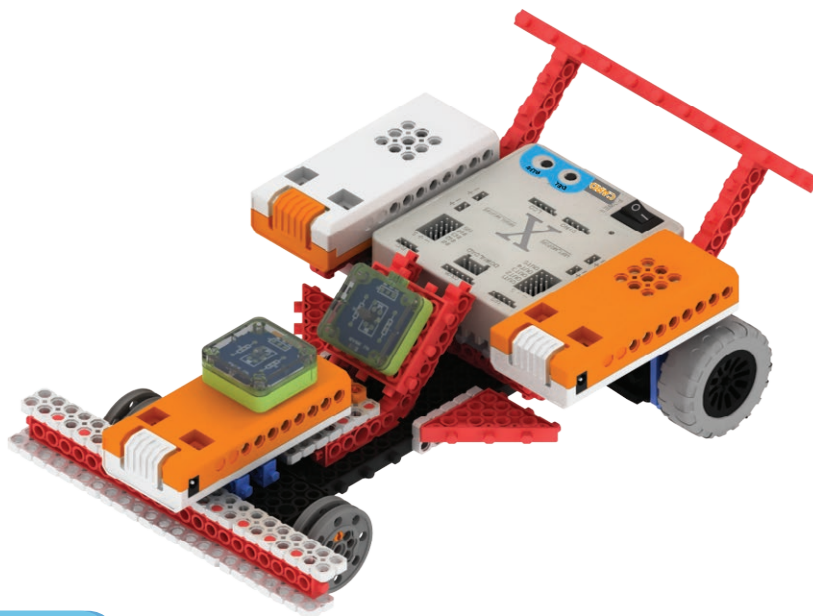

19 Mașină de curse

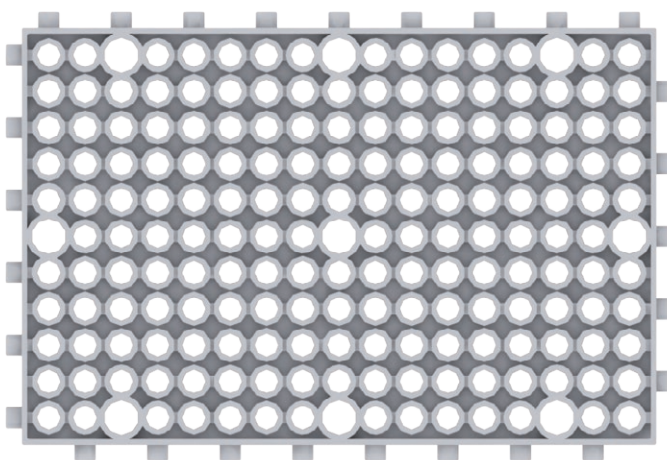

Piese



Bloc 11x17 (1)



Bloc N 2x5 (2)



Bloc N 2x7 (5)



Bloc N 3x7 (1)



Bloc N 2x9 (2)



Nit
clasic (8)



Nit dublu
de tip 1 (2)



Piuliță (4)

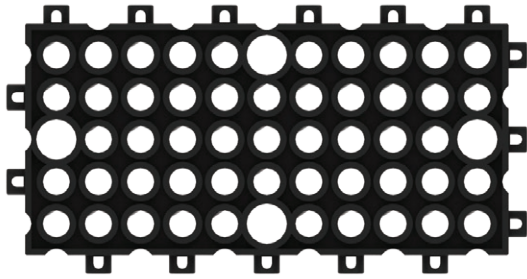

Bloc 5x11 (1)

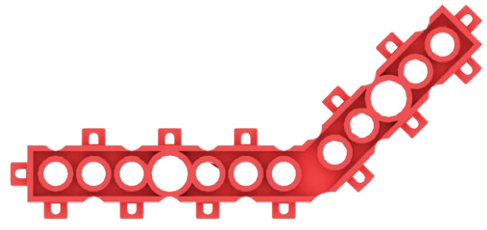

Bloc 135° (4)

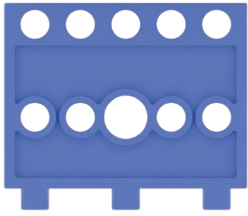

Suport de motor (2)

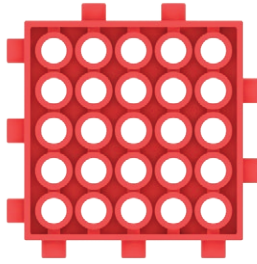

Bloc 5x5 (1)

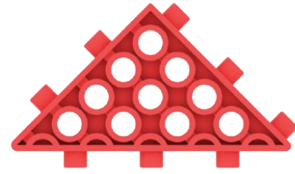

Bloc triunghiular (2)

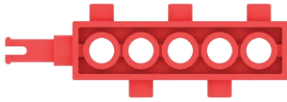

Bloc cu ax (4)

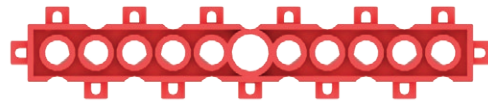

Bloc 1x11 (4)

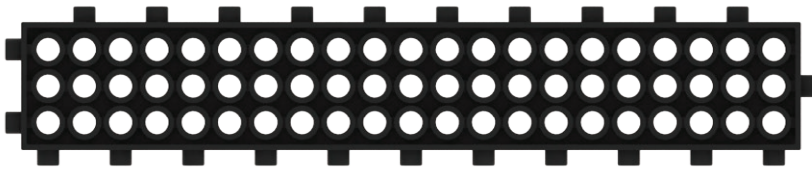

Bloc 3x21 (2)

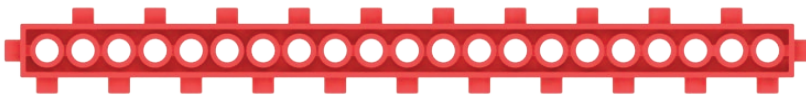

Bloc 1x21 (2)

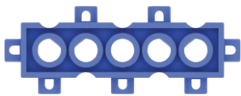

Bloc 1x5 (2)



Jantă/Hub 1 (2)



Jantă/Hub 2 (4)



Motor 2 (2)

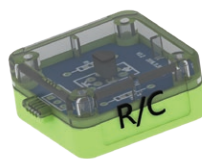

Senzor R/C (1)

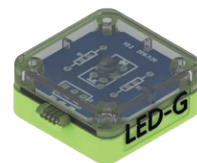

LED G (1)

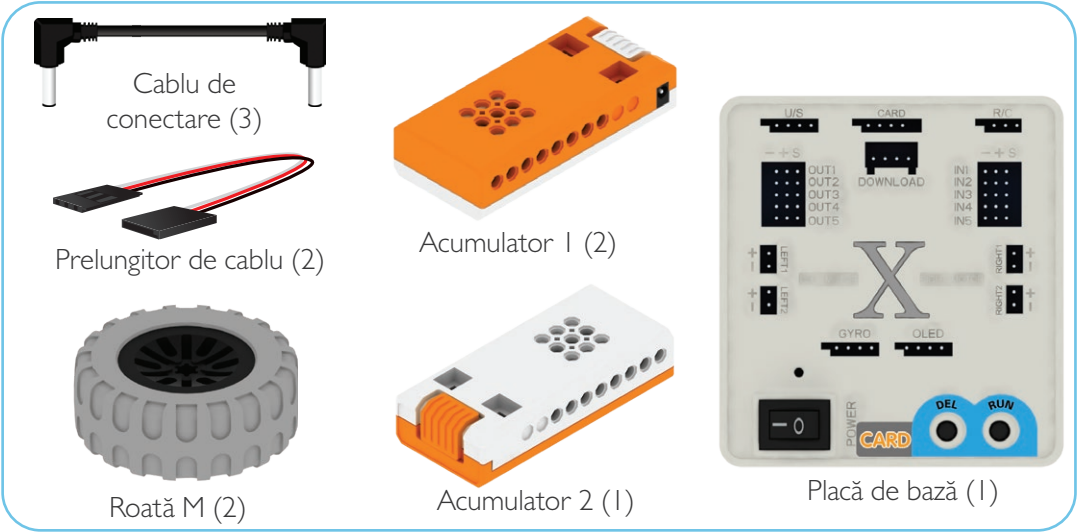

01

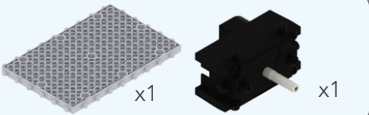
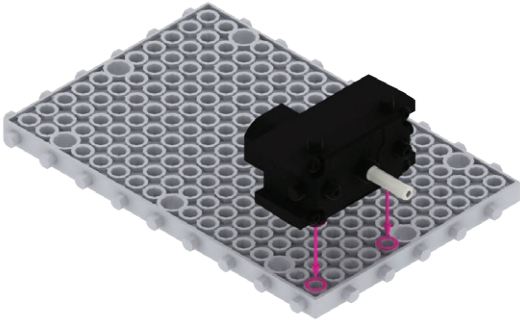

02

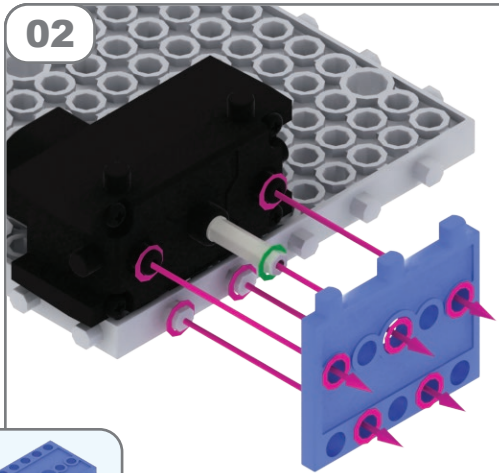

03

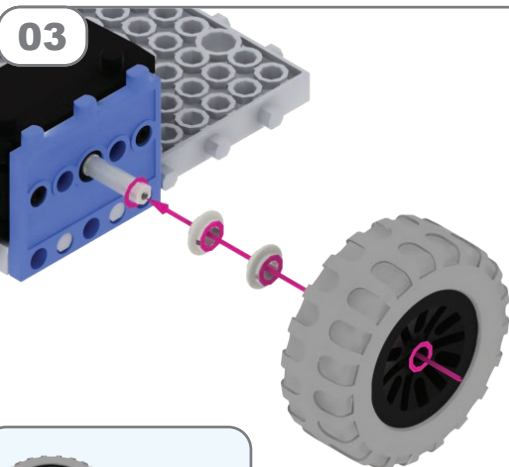

04

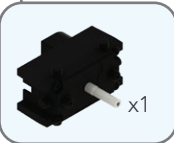
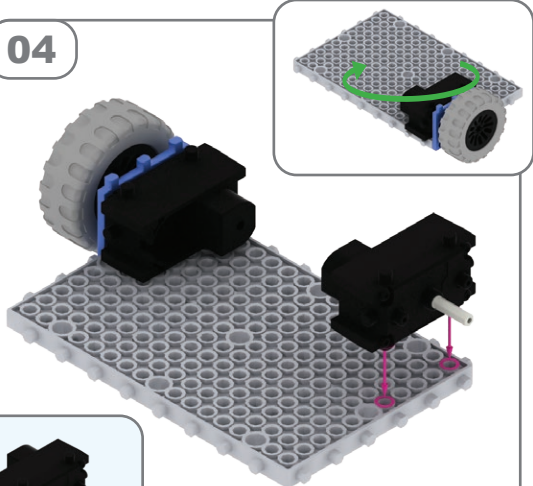

05

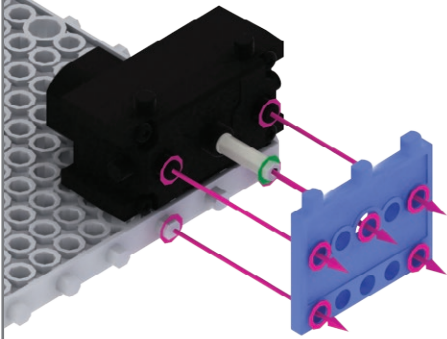

06

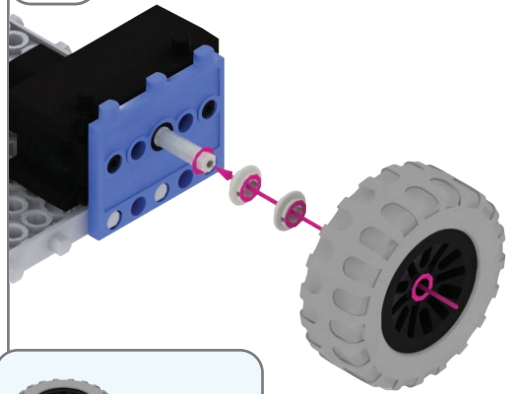

07

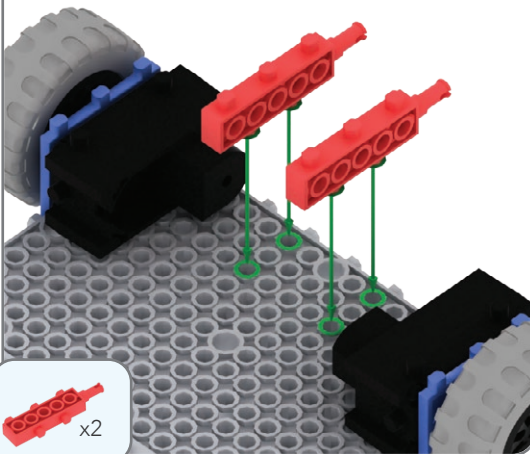

08

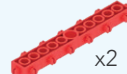
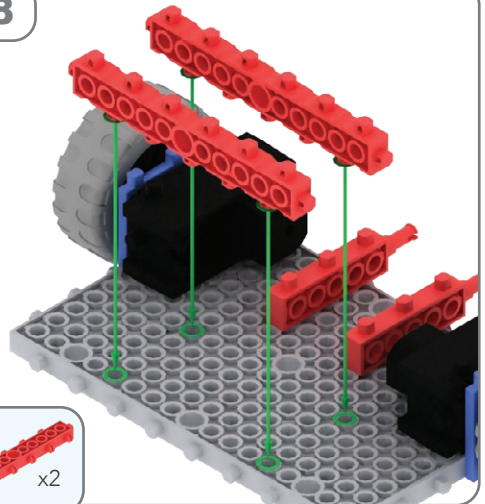

09

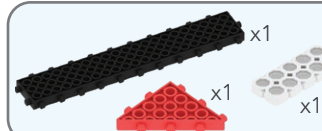
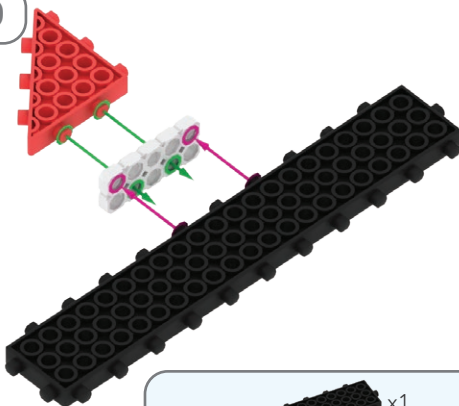

10

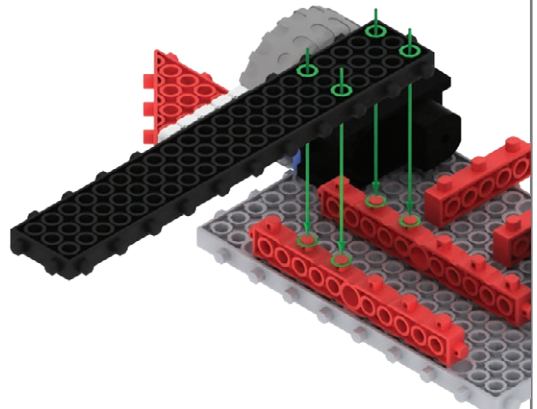

11

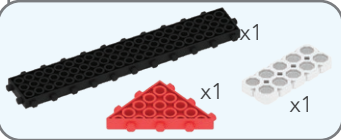
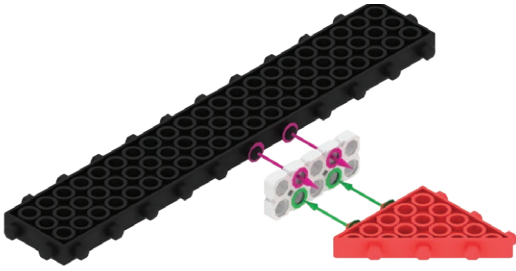

12

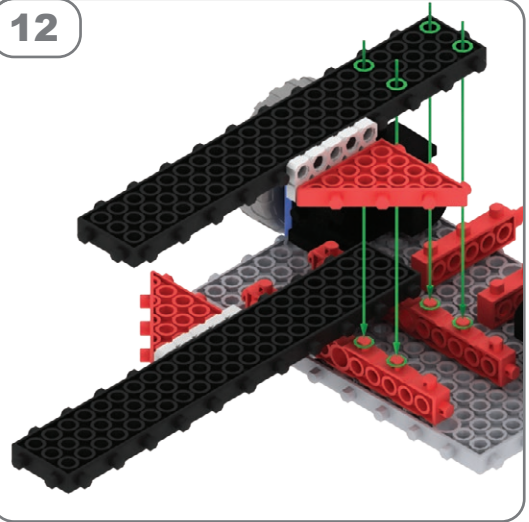

13

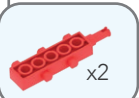
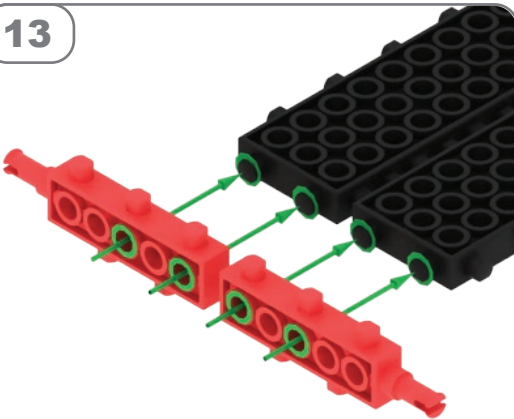

14

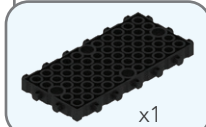
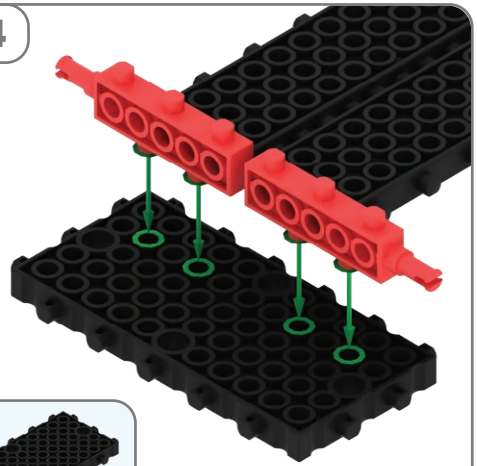

15

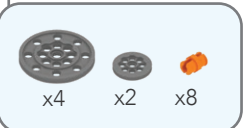
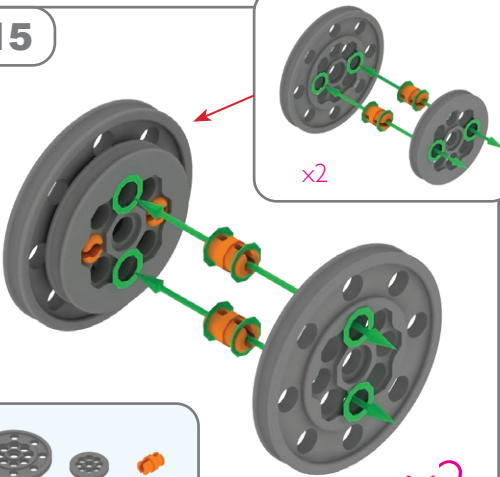

16

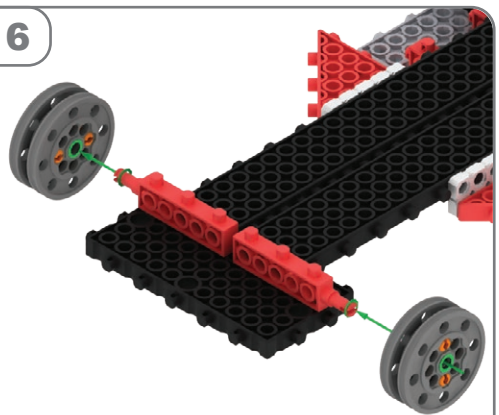

17

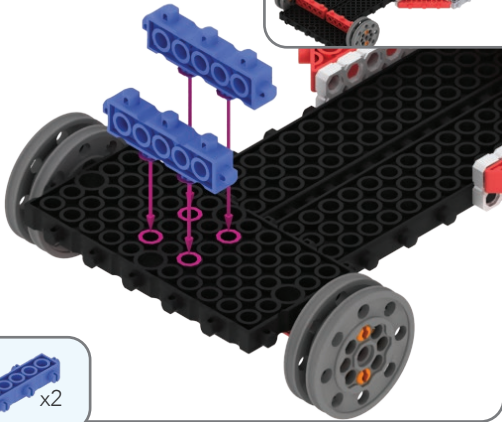

18

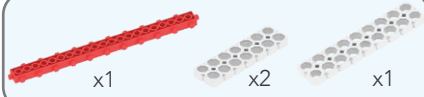
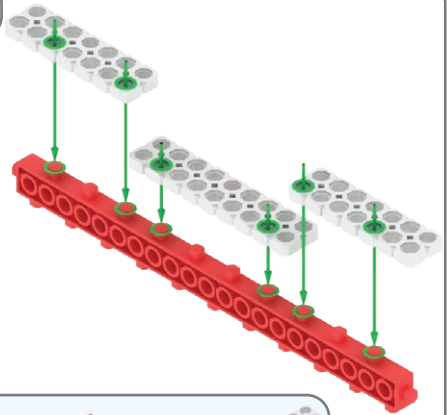

19

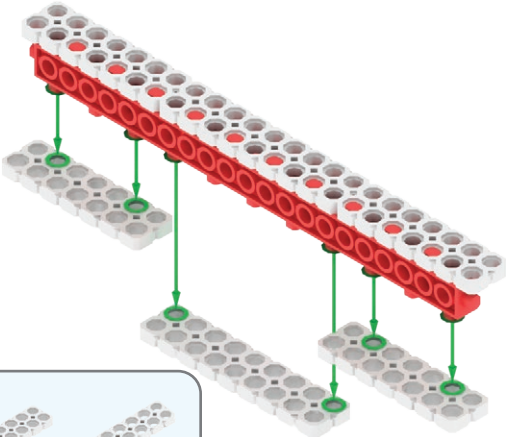

20

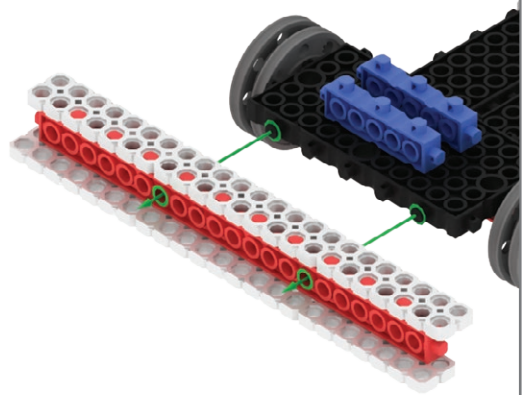

21

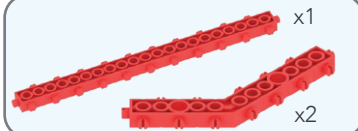
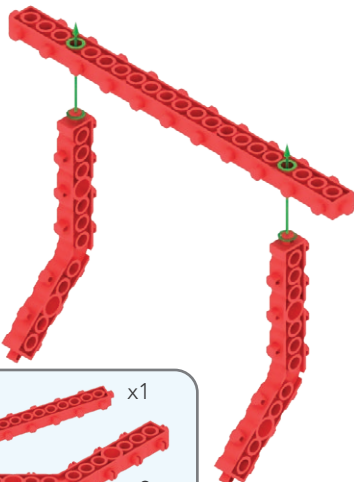

22

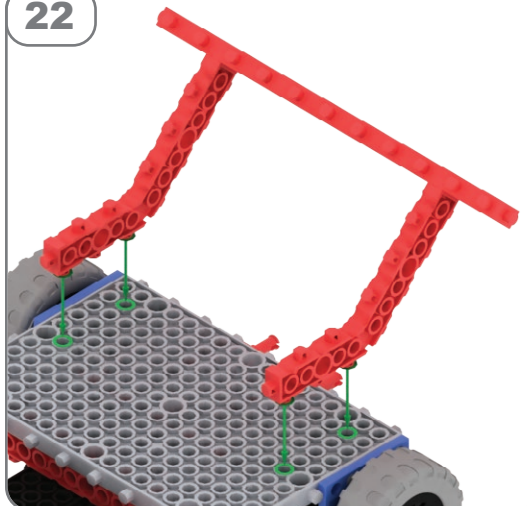

23

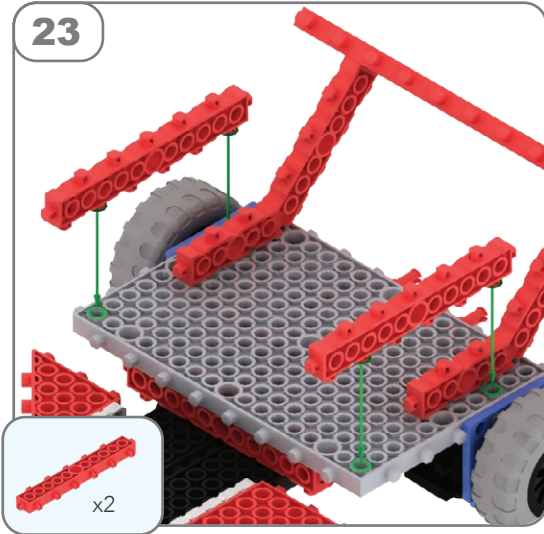

24

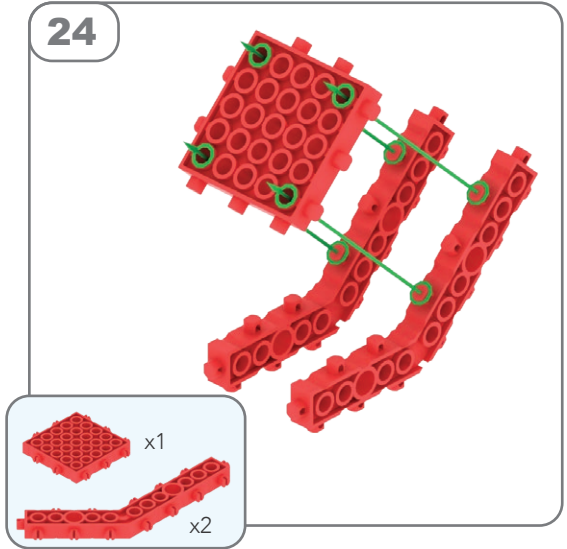

25

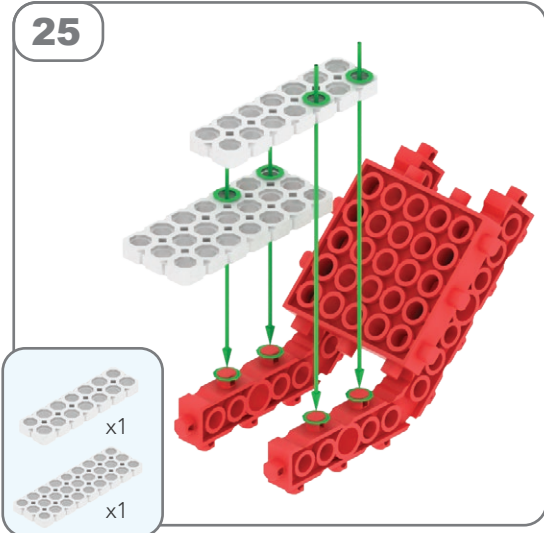

26

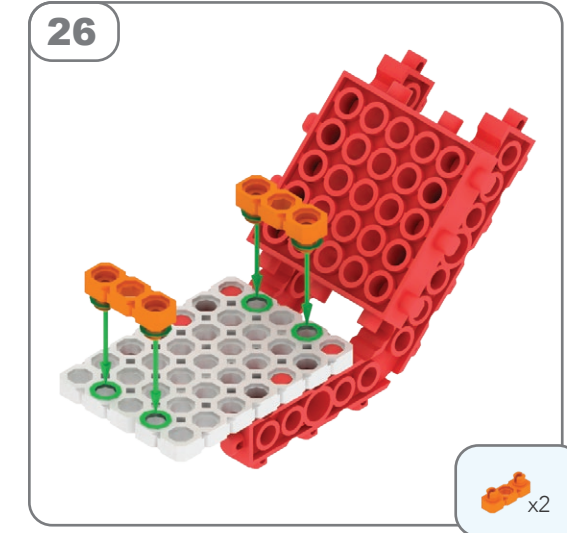

27

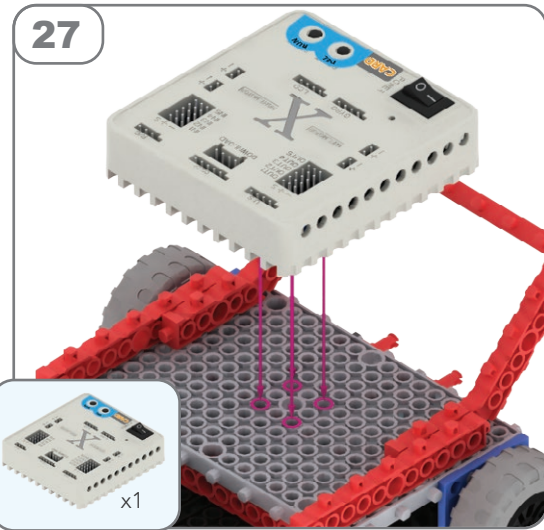

28

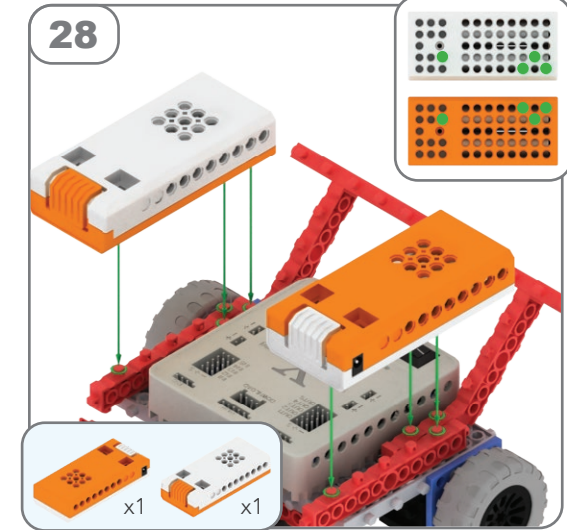

29

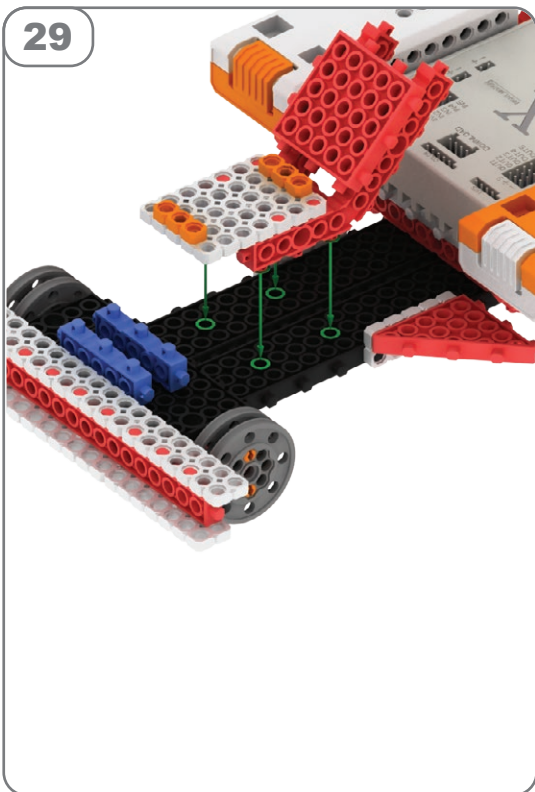

30

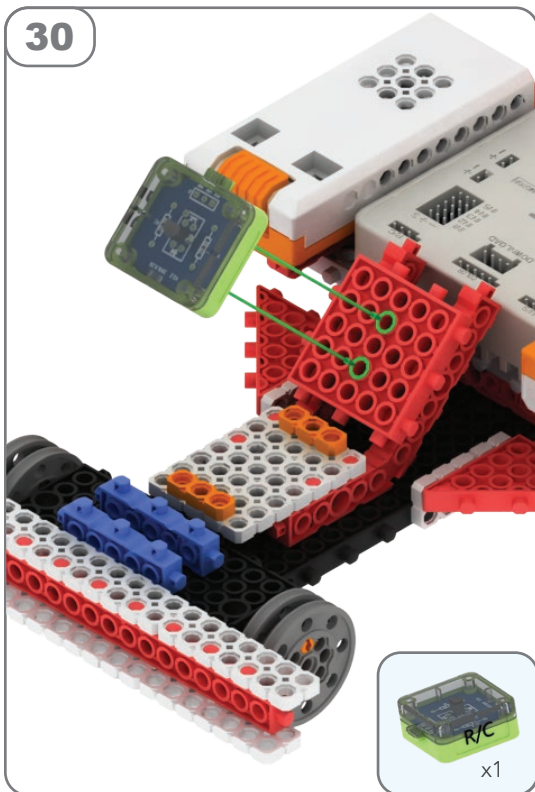

31

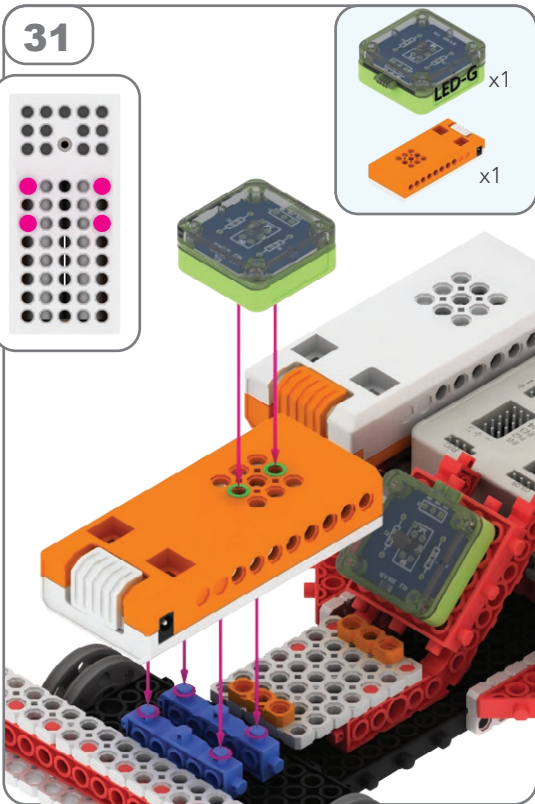

OK

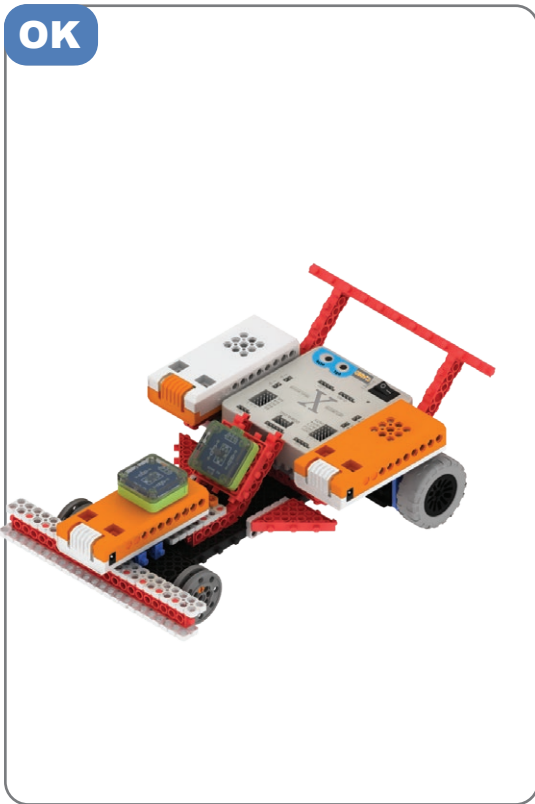

Cum se conectează?

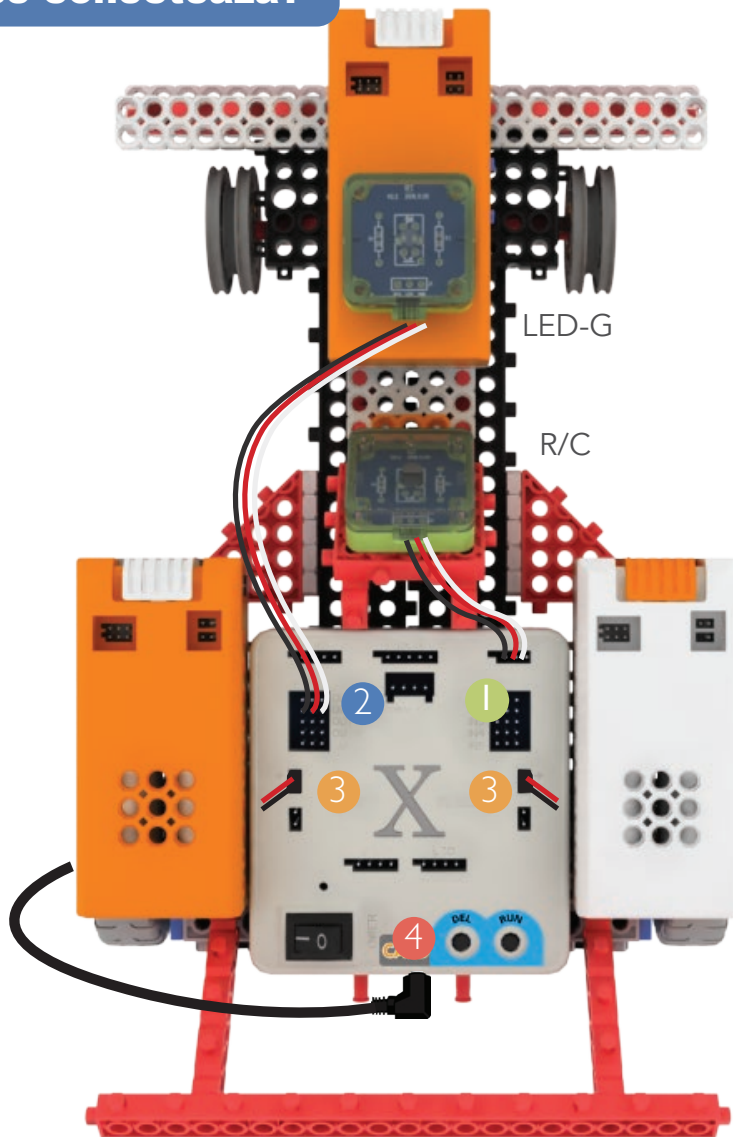

- 1 Conectează senzorul R/C la placa de bază, cum îți se arată mai sus.
- 2 Conectează LED G la portul OUT2.
- 3 Conectează cele două motoare la placă.
- 4 Conectează acumulatorul la placă.

Acumulatorii vor furniza energie când sunt conectați la placă prin cablul negru, indiferent de poziția întrerupătoarelor.

Practica

Pornește placa de bază apăsând pe POWER, apoi pe RUN și apoi pe DEL de cinci ori. X va pâlpâi în albastru, apoi apasă pe RUN pentru a activa modul 6.

Folosește telecomanda pentru a controla mașina.

