



20 Fotbalist



Piese



Bloc N 3x11 (2)



Bloc N 3x9 (2)



Bloc N 2x11 (2)

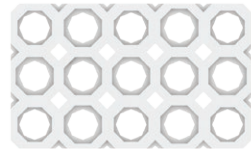

Bloc N 3x5 (1)



Adaptor L (4)



Bloc N 1x5 (3)



Cauciuc roșu de ax /
Red bush (2)



Piuliță (12)

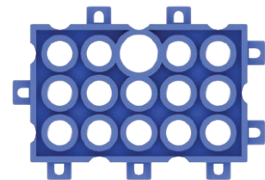

Bloc 3x5 (5)

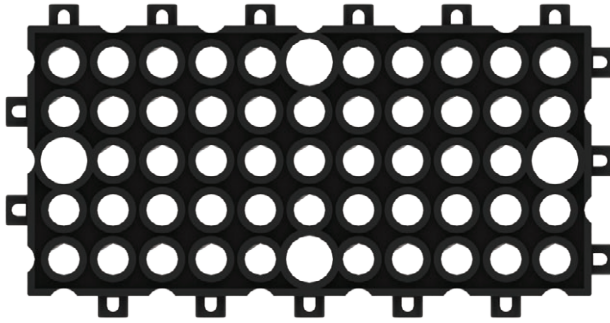

Bloc 5x11 (5)

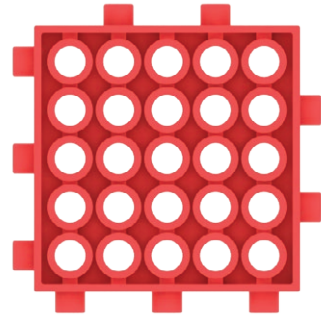

Bloc 5x5 (4)

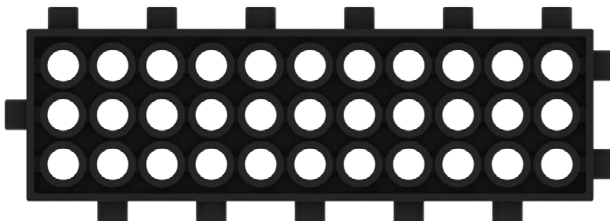

Bloc 3x11 (4)

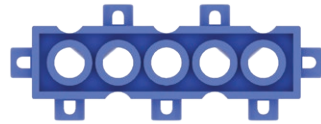

Bloc 1x5 (1)

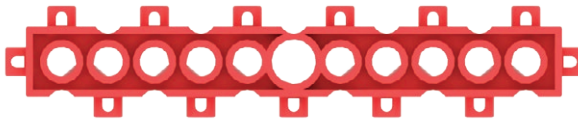

Bloc 1x11 (4)

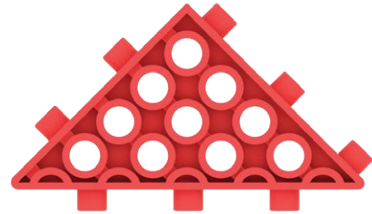

Bloc triunghiular (4)

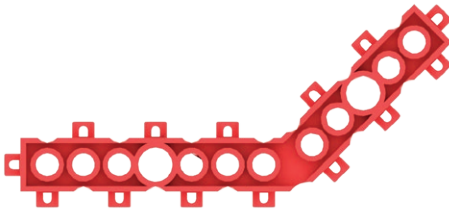

Bloc de 135° (6)



Roată M (2)



Minge de fotbal (1)



Angrenaj M (2)



Angrenaj L (2)



Bloc de îmbinare 2 (2)

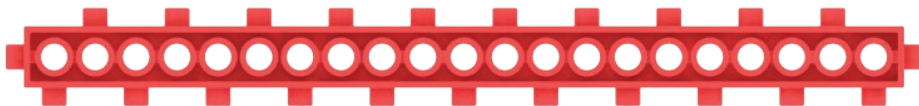

Bloc 1x21 (2)

L-shaft

Ax L (2)



Motor 2 (2)

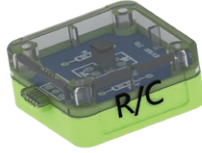

Senzor R/C (1)



LED Y (1)

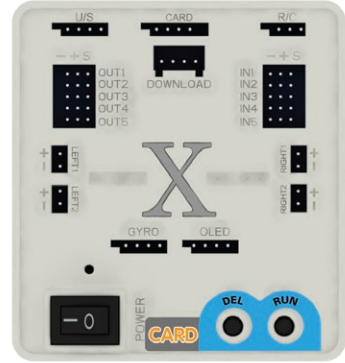

Placă de bază (1)



Cablu de conectare (3)

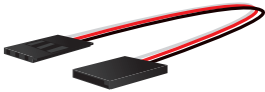

Prelungitor (2)

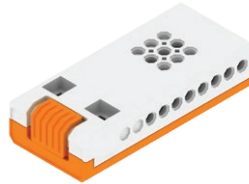

Acumulator 1 (1)



Acumulator 2 (2)

01

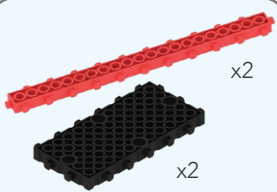
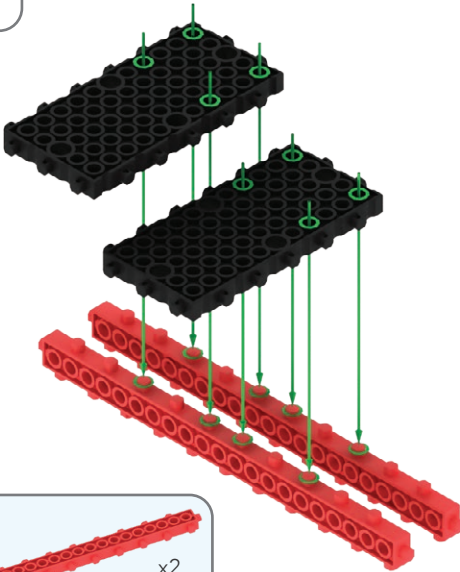

02

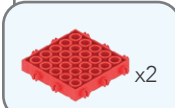
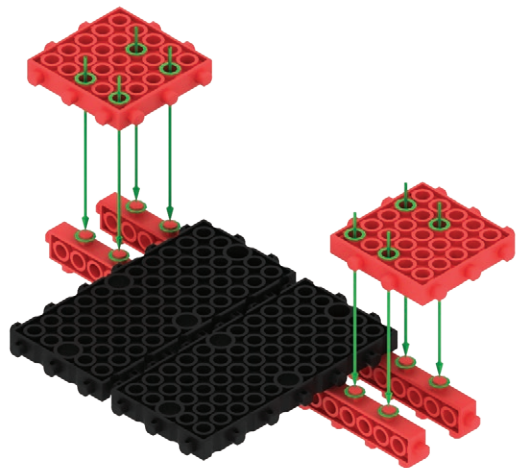

03

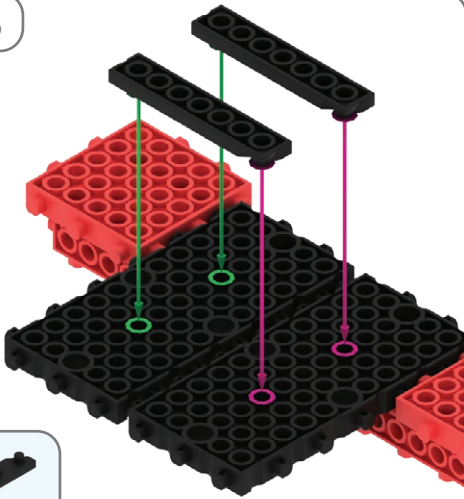

04

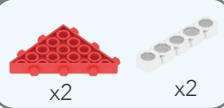
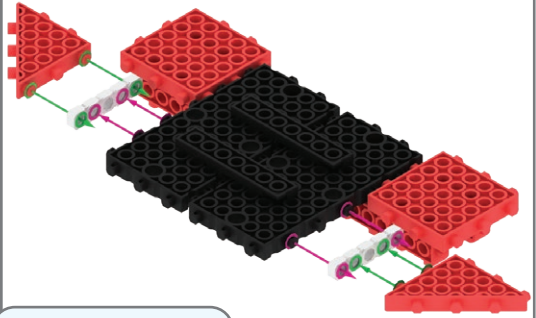

05

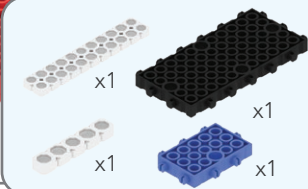
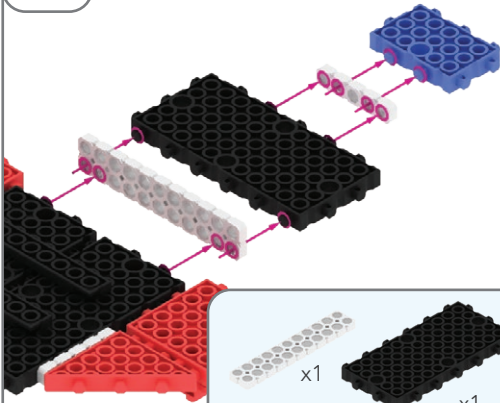

06

Notă: triunghiul roșu ▲ indică poziția.

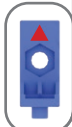
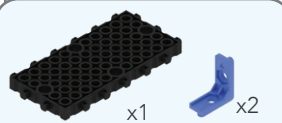
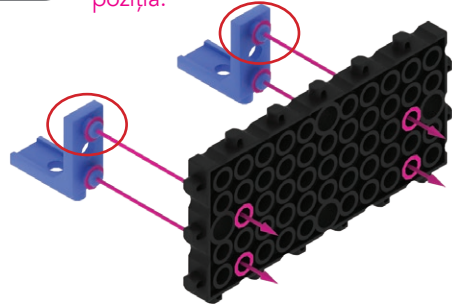

07

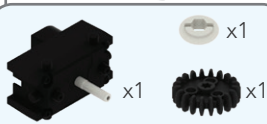
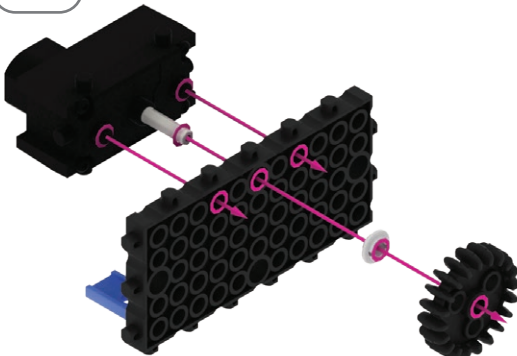

08

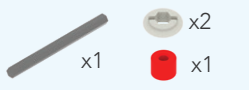
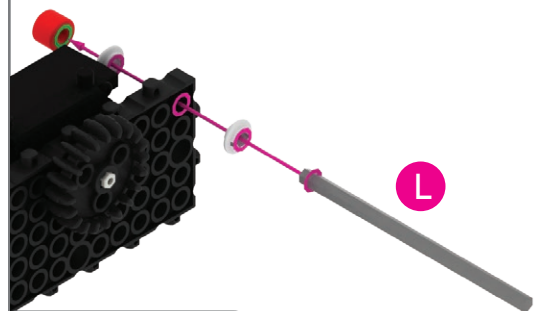

1:1

09

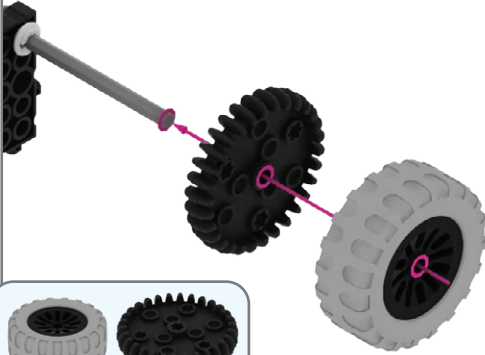

10

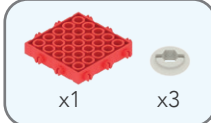
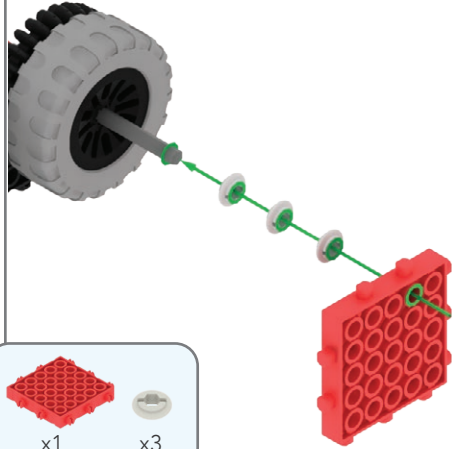

11

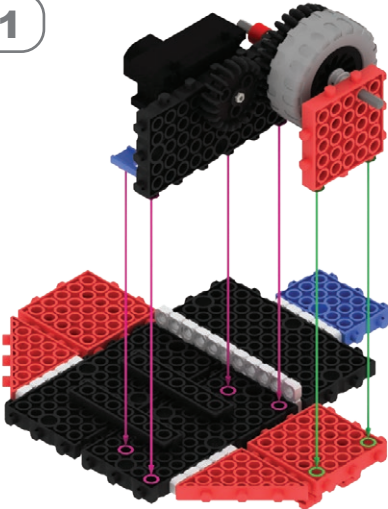

12

Notă: triunghiul roșu ▲ indică poziția.

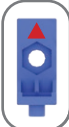
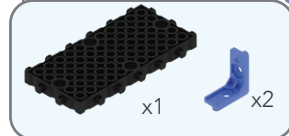
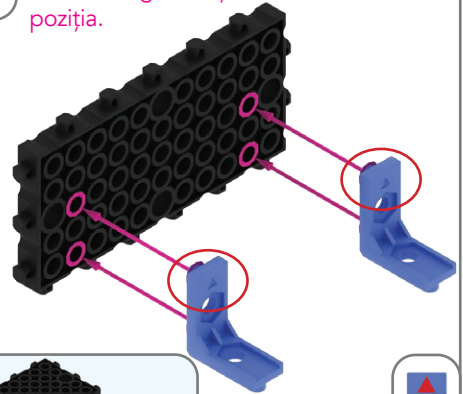

13

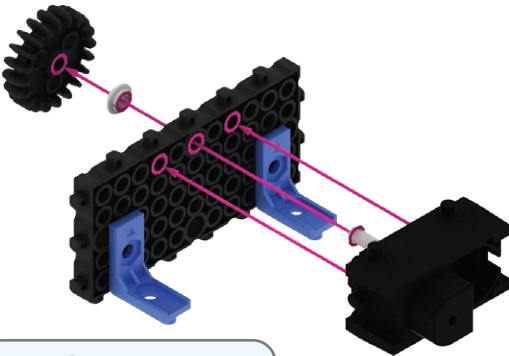

14

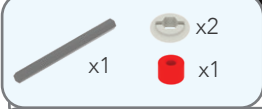
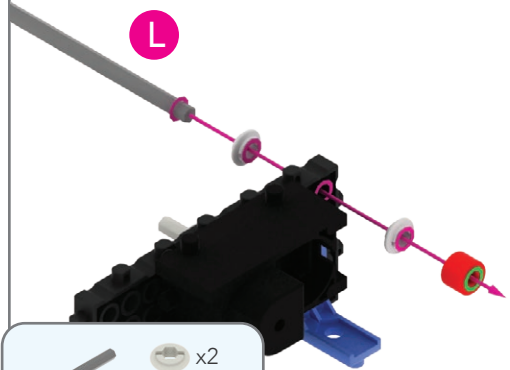

1:1

15

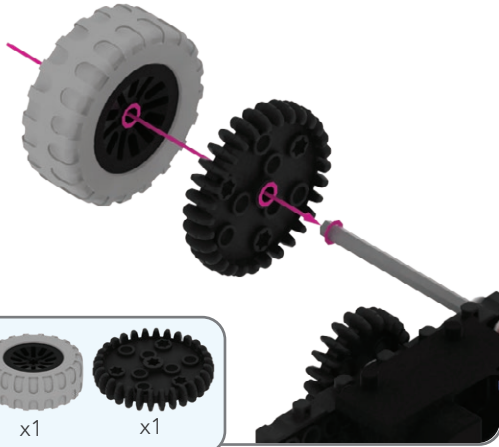

16

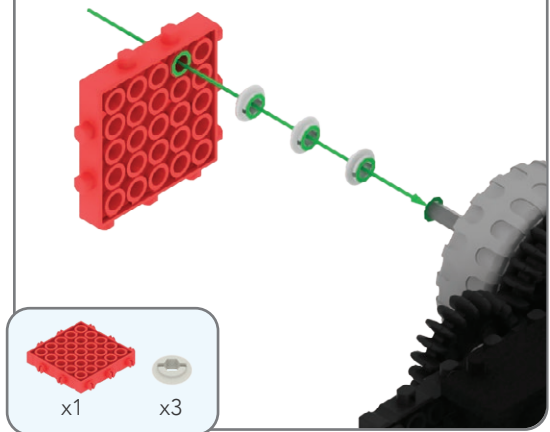

17

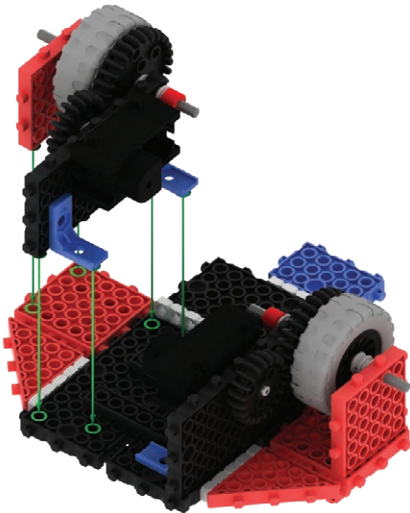

18

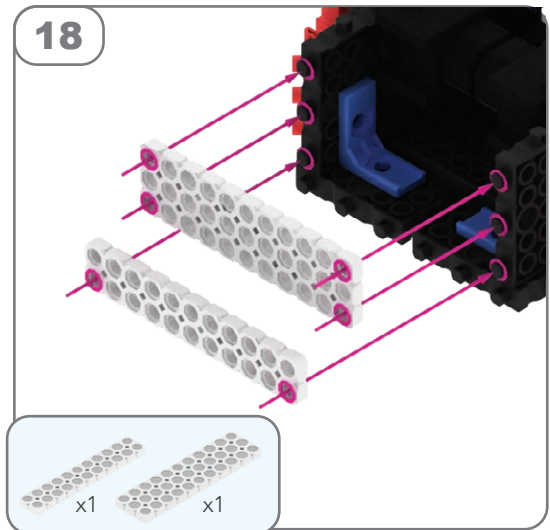

19

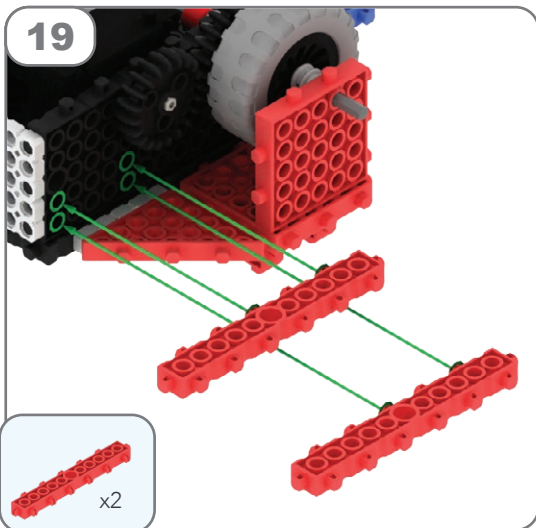

20

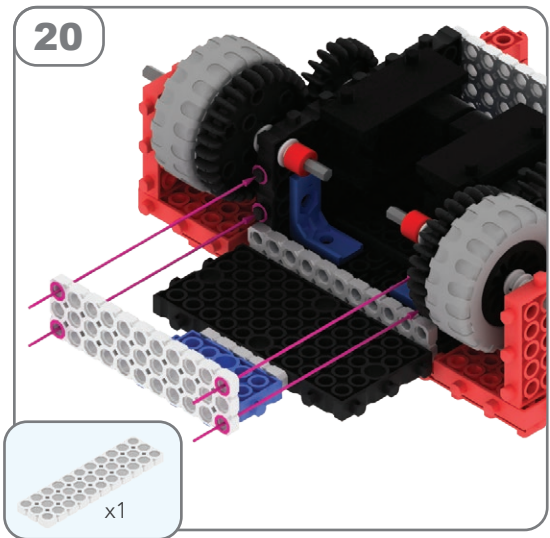

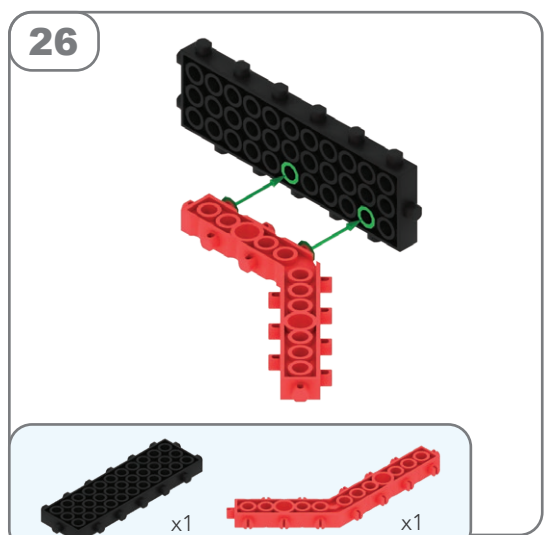
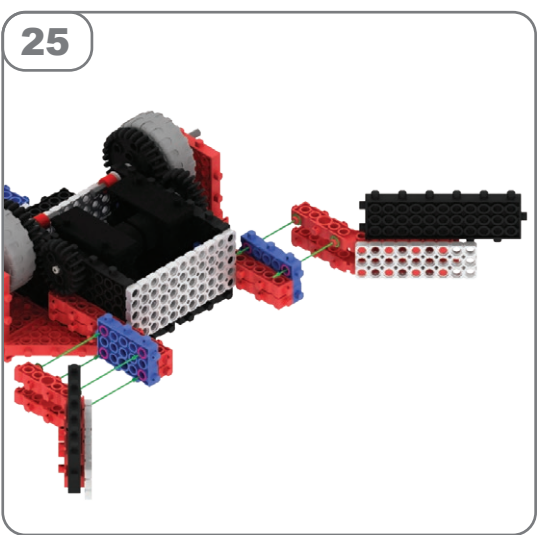
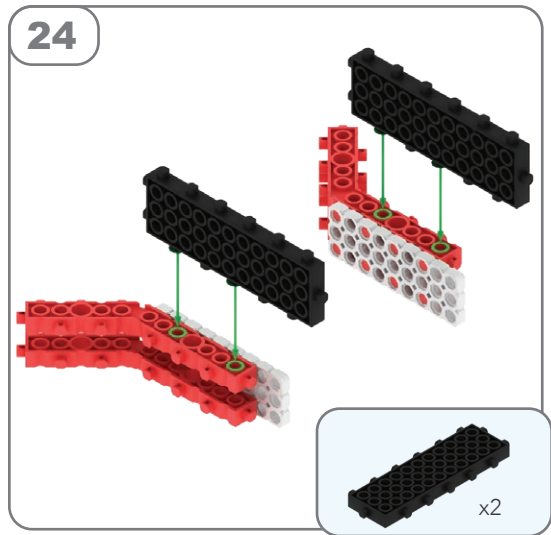
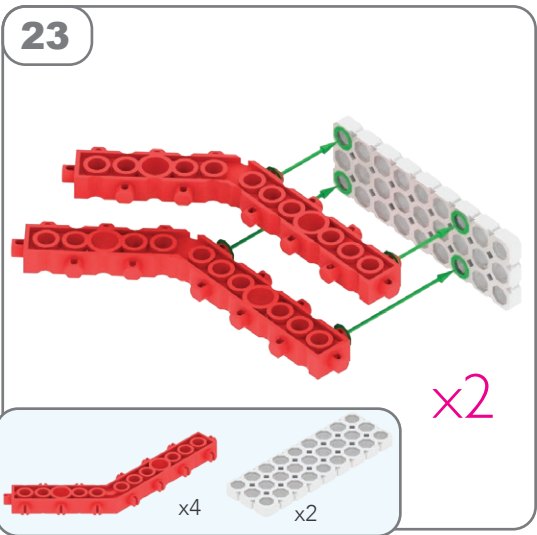
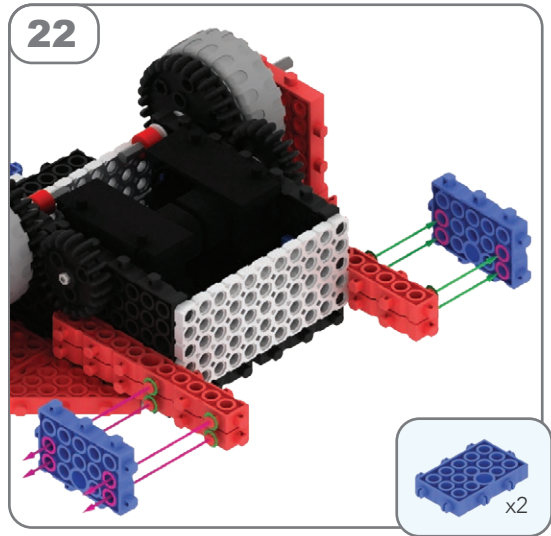
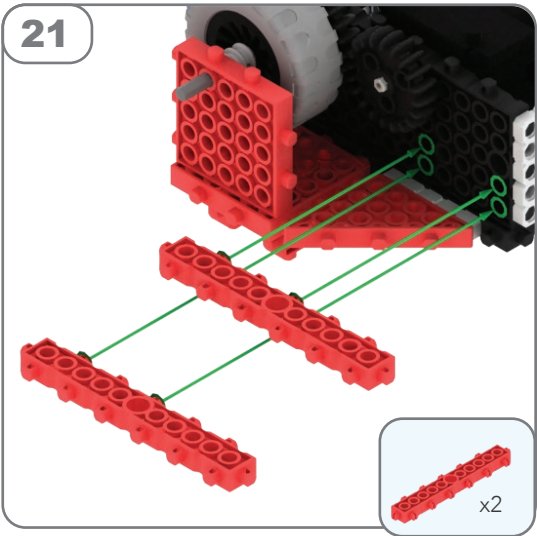

27

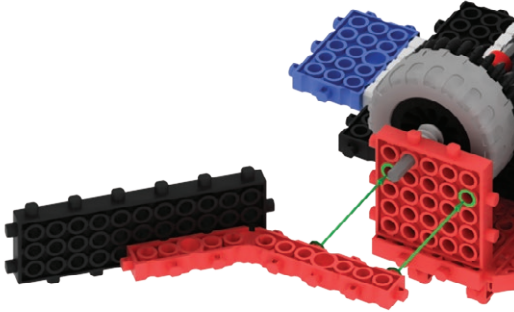

28

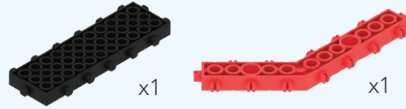
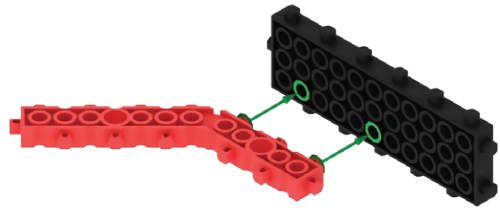

29

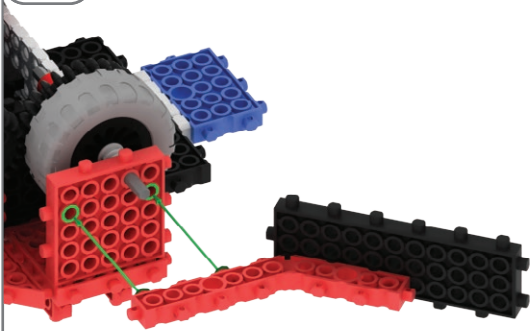

30

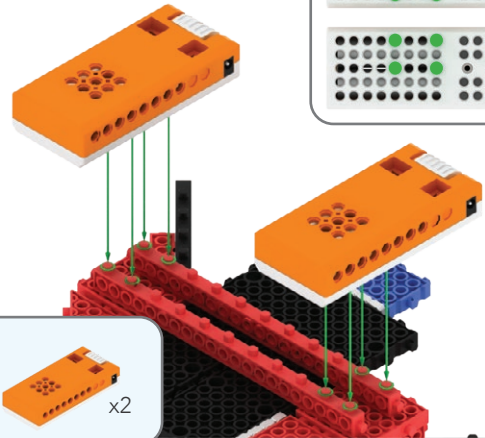

31

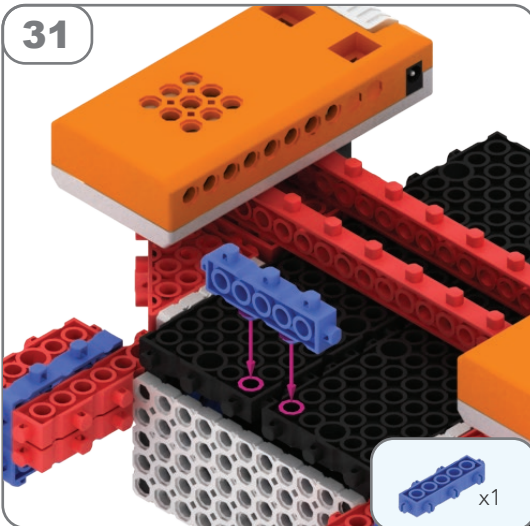

32

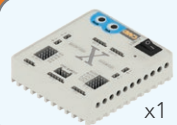
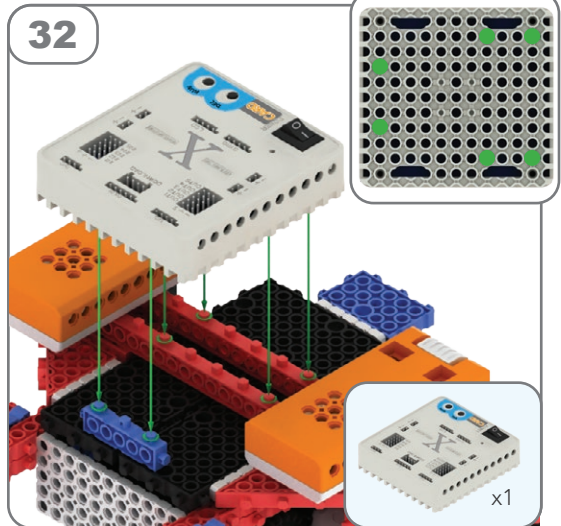

33

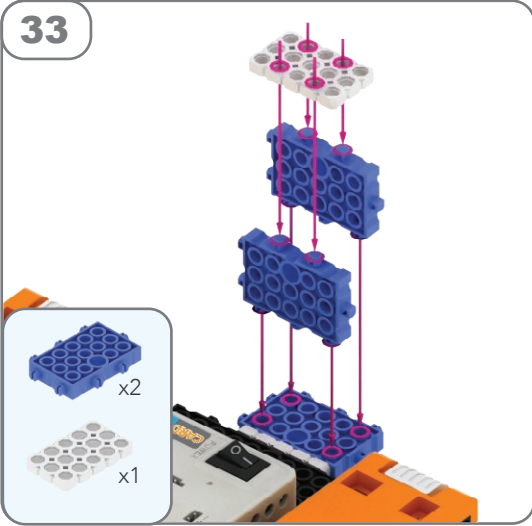

34

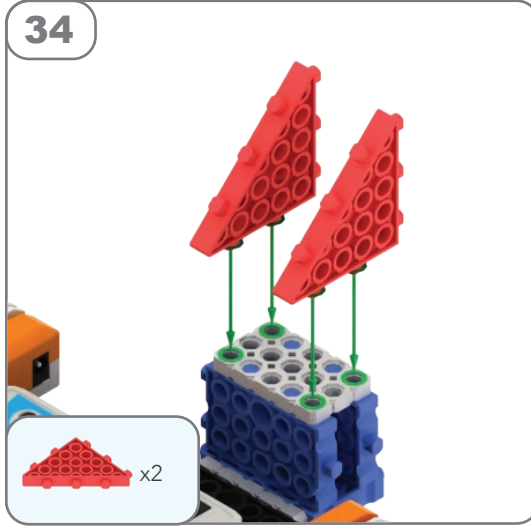

35

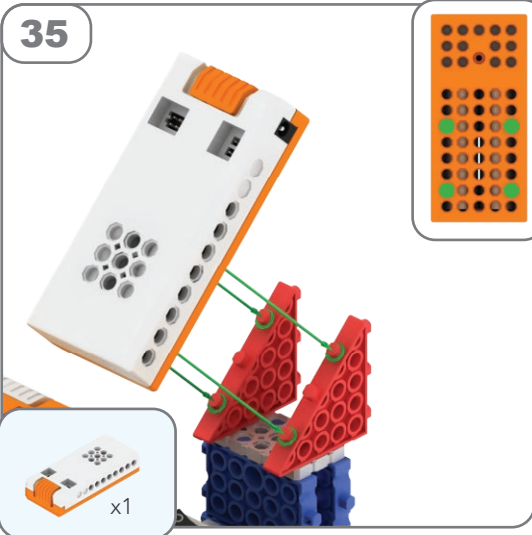

36

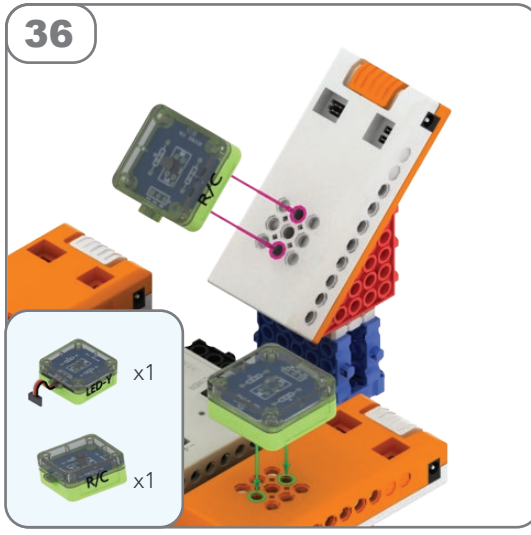

OK

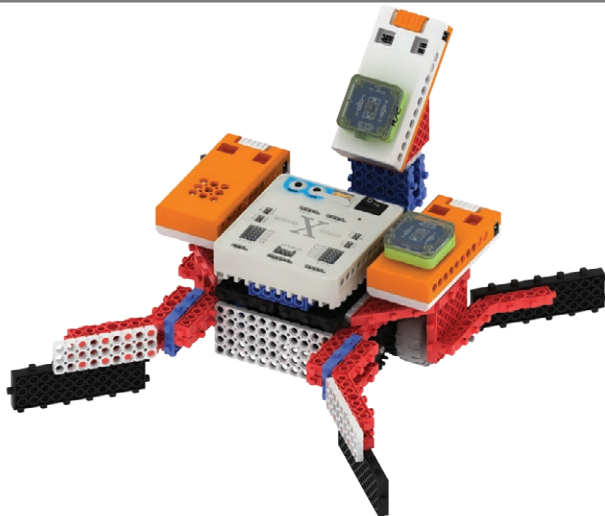

Cum se conectează?

- 1 Conectează senzorul R/C la placa de bază, cum ți se arată în imagine.
- 2 Conectează cele două motoare la placa de bază. **Observă că firul negru se conectează la +.**
- 3 Conectează LED Y la portul OUT2.
- 4 Conectează acumulatorul la placa de bază.

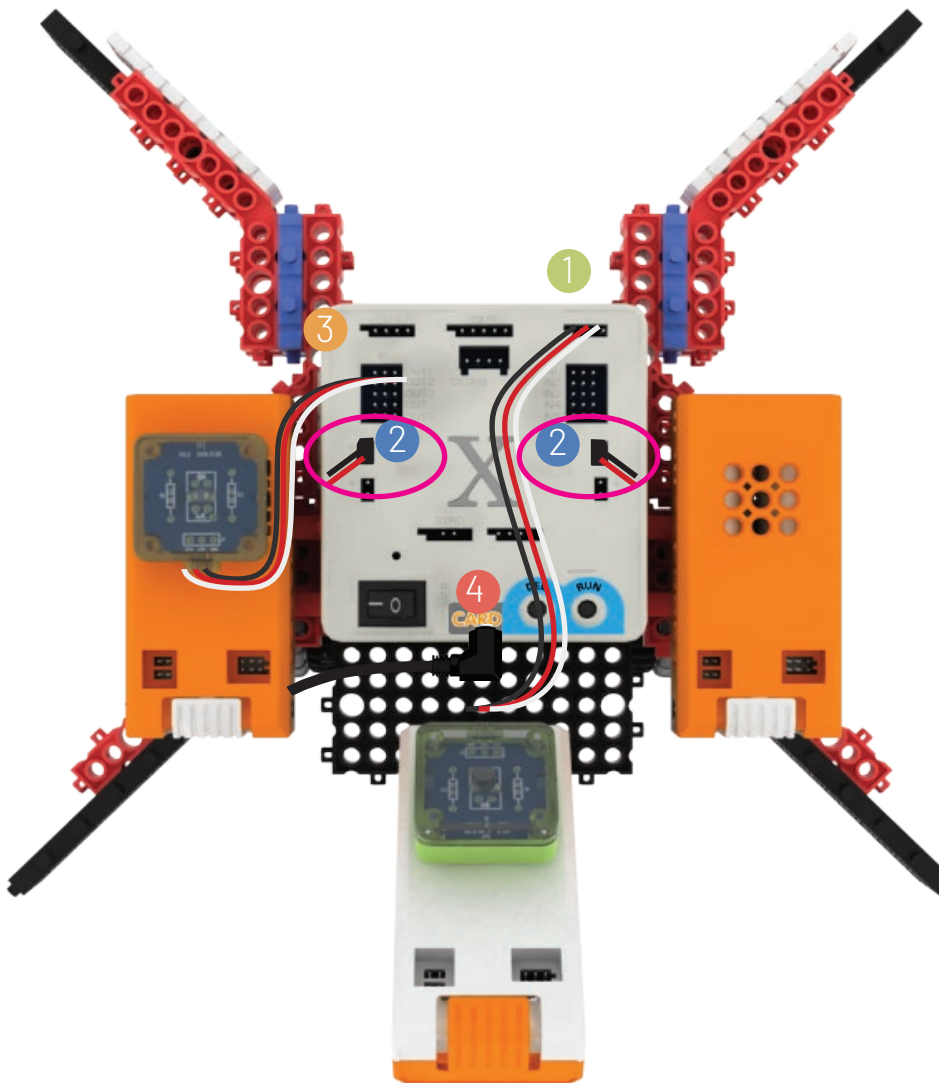

Practica

Pornește placa de bază apăsând pe POWER, apoi pe RUN și apoi pe DEL de cinci ori. X va pălpâi în albastru, apoi apasă pe RUN pentru a activa modul 6.

Folosește telecomanda pentru a controla robotul fotbalist.

Construiește o poartă, joacă-te cu robotul tău și marchează un gol!

