

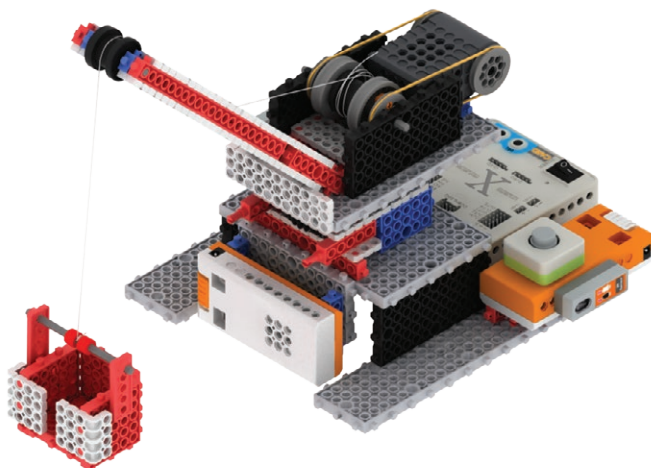

30 Macara



Piese



Bloc N 3x11 (2)



Bloc N 3x9 (2)



Bloc N 2x13 (4)



Bloc N 2x7 (2)



Bloc N 2x11 (4)



Bloc N 2x9 (2)



Bloc N 3x7 (2)



Nit dublu (2)



Roată de direcție (2)

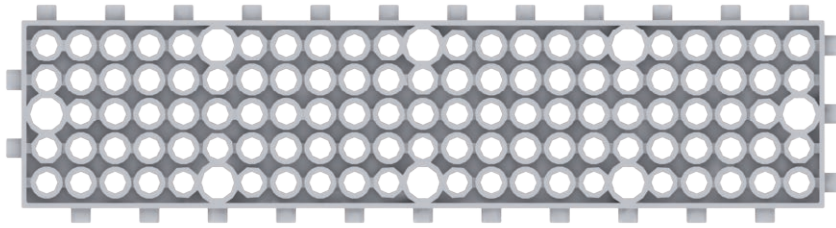

Bloc 5x23 (2)

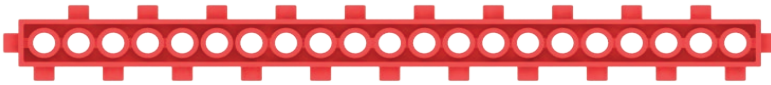

Bloc 1x21 (2)



Angrenaj simplu
(1)

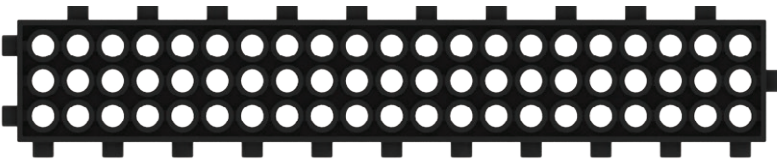

Bloc 3x21 (1)



Adaptor L
2x4 (4)

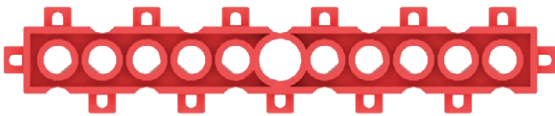

Bloc 1x11 (3)

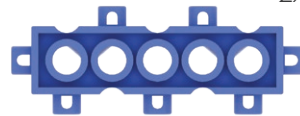

Bloc 1x5 (6)



L-shaft

Ax L (3)



M-shaft

Ax M (2)



Conector de ax (2)

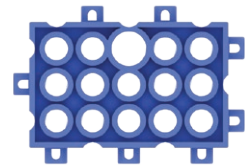

Bloc 3x5 (2)



Piuliță (2)



Cauciuc roșu de ax (7)

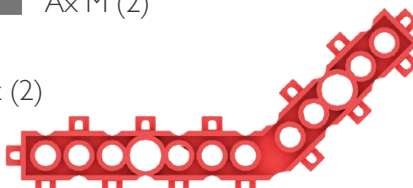

Bloc de 135 ° (2)



Elastic (2)



Bloc de îmbinare 2 (2)



Motor 2 (1)

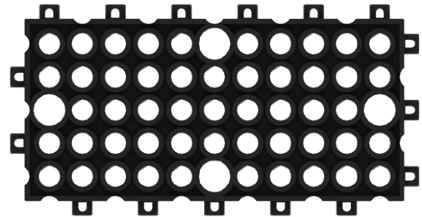

Bloc 5x11 (5)



Bloc cu ax (4)



Angrenaj L (2)



Angrenaj M (1)



Angrenaj S (2)



Jantă (2)

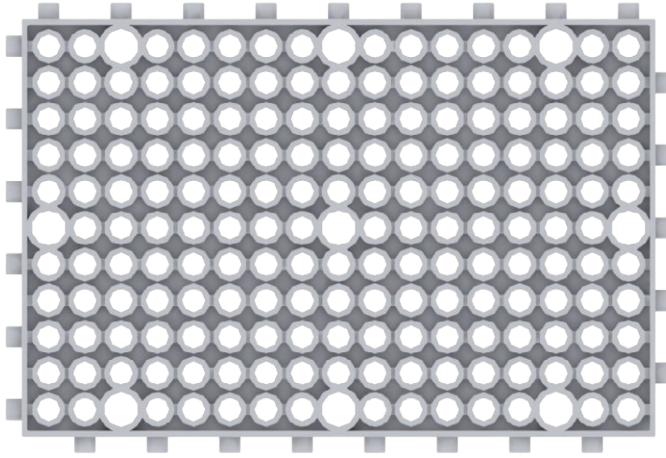

Bloc 11x17 (2)

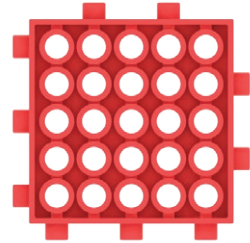

Bloc 5x5 (4)



Jantă de roată subțire (2)



Senzor cu infraroșu (2)



Buton (2)



Manivelă (2)



Motor 1 (1)



Cablu de conexiune (3)

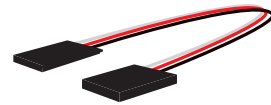

Prelungitor (2)

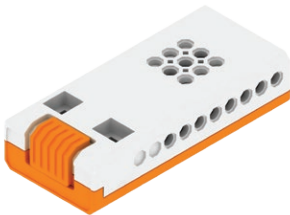

Acumulator 1 (1)



Acumulator 2 (2)

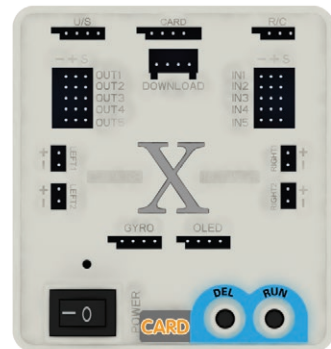

Placă de bază MRT-Card (1)

13

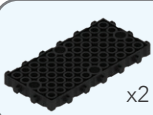
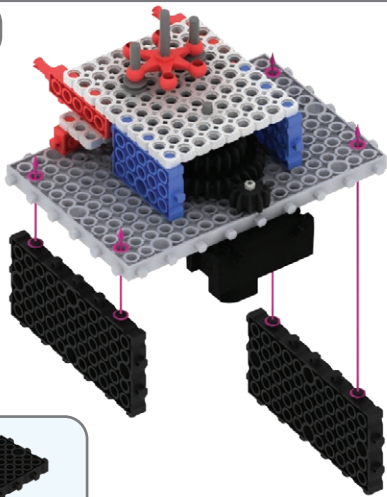

14

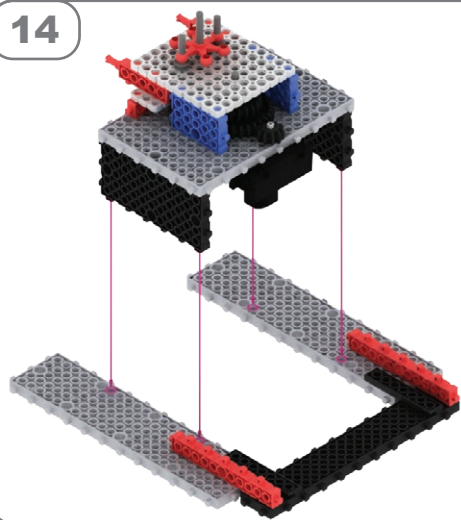

15

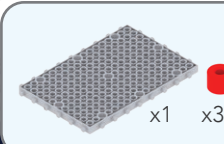
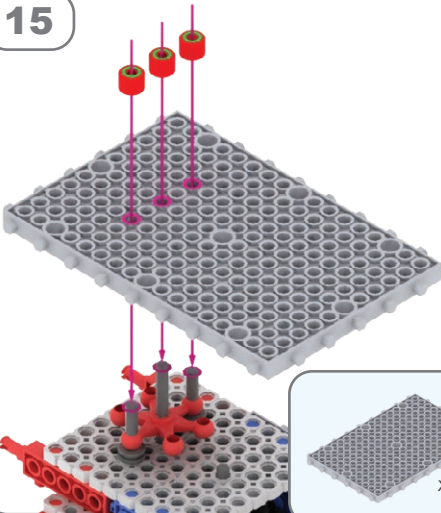

16

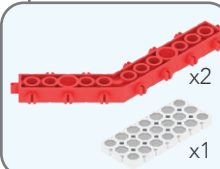
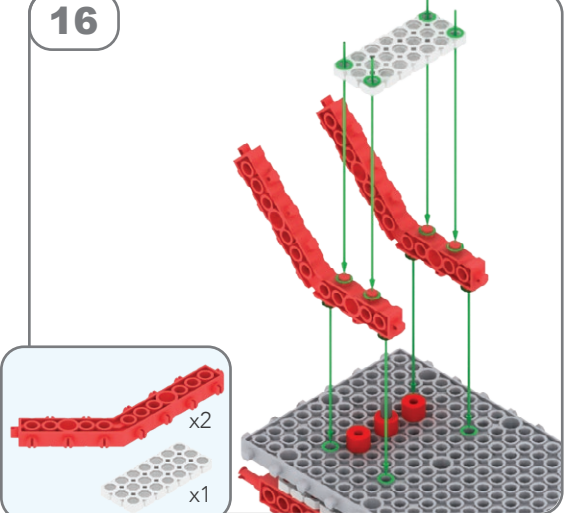

17

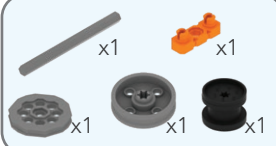
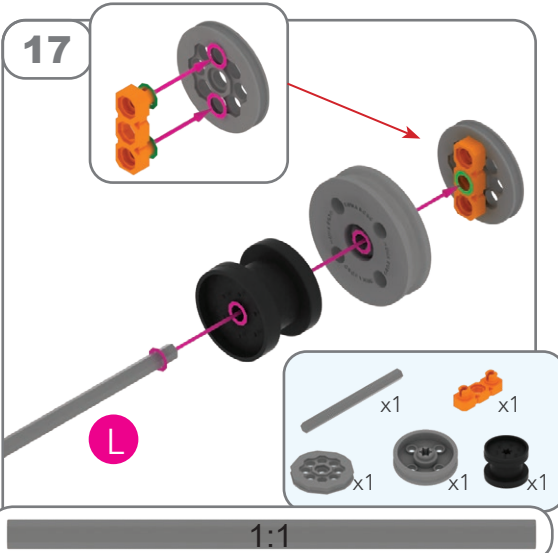

18

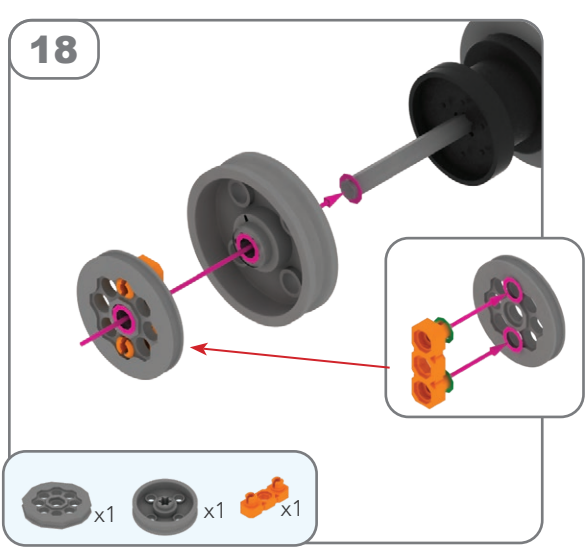

19

Fixează elasticele pe jante/Hub1

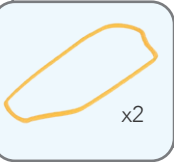
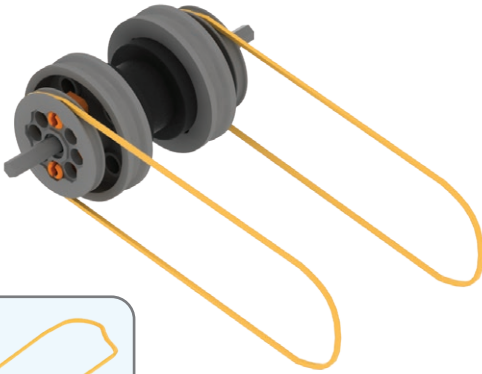

20

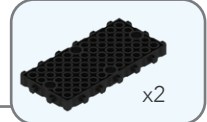
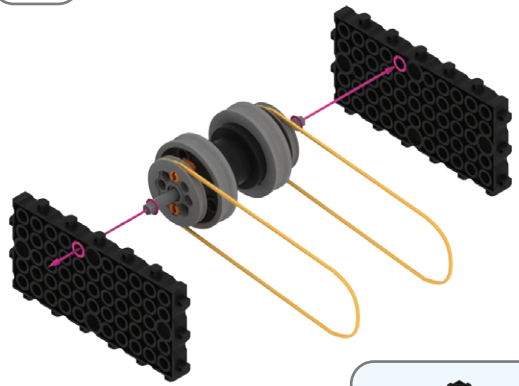

21

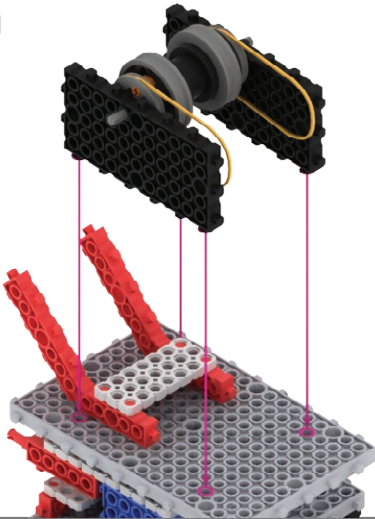

22

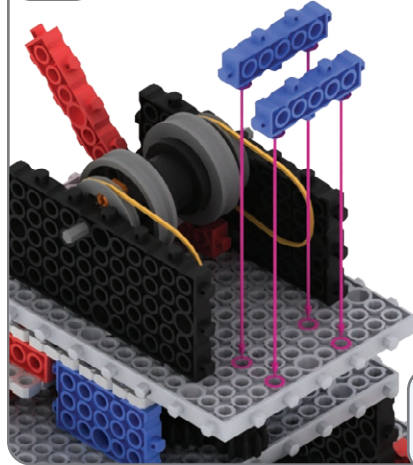

23

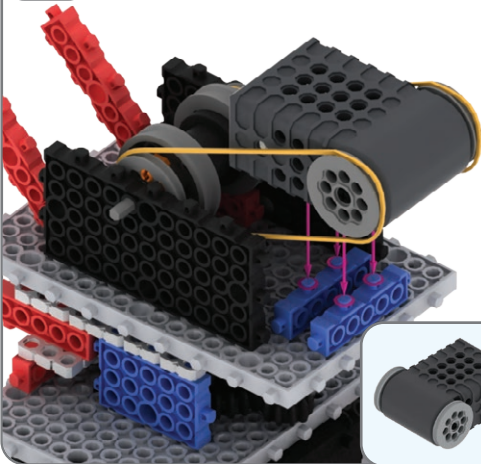

24

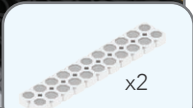
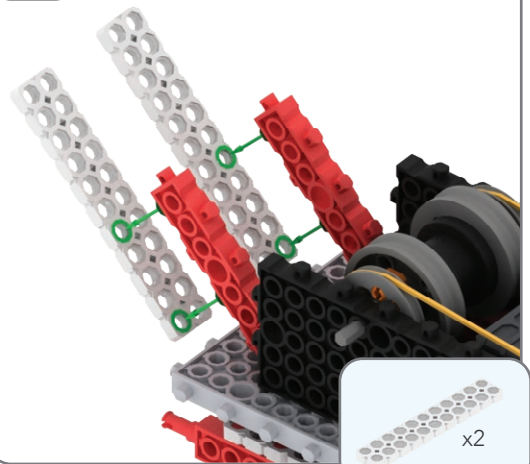

25

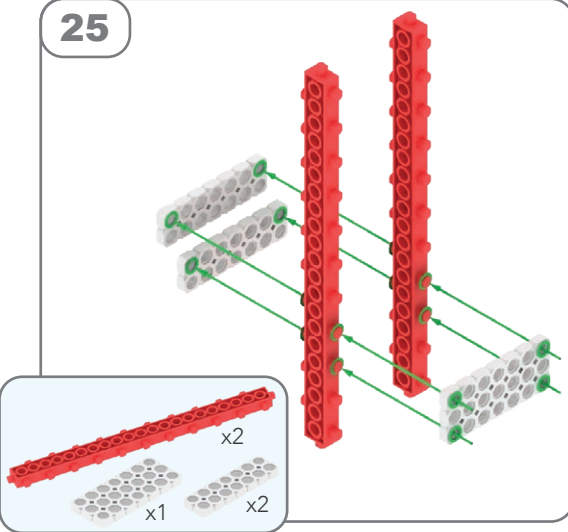

26

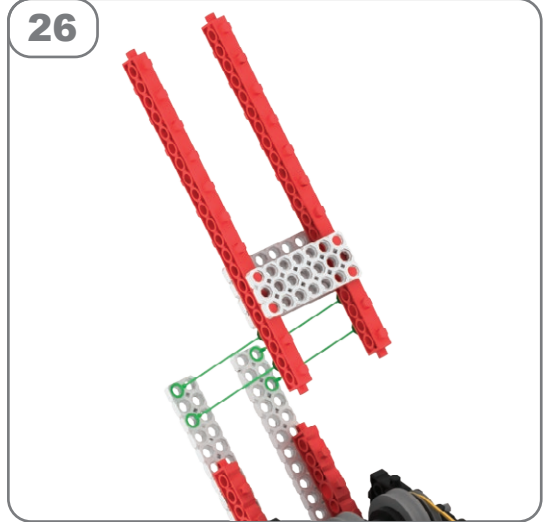

27

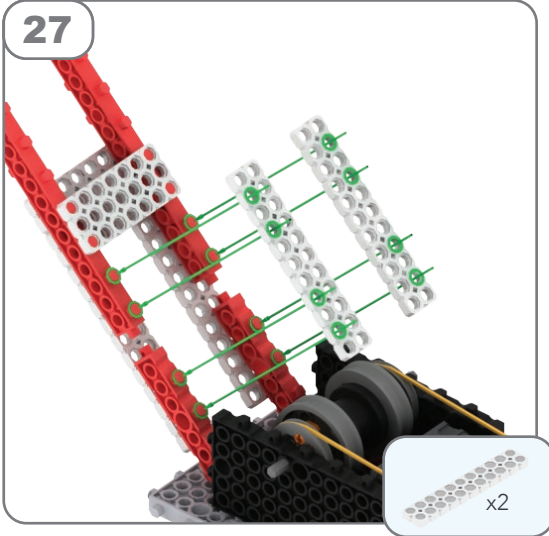

28

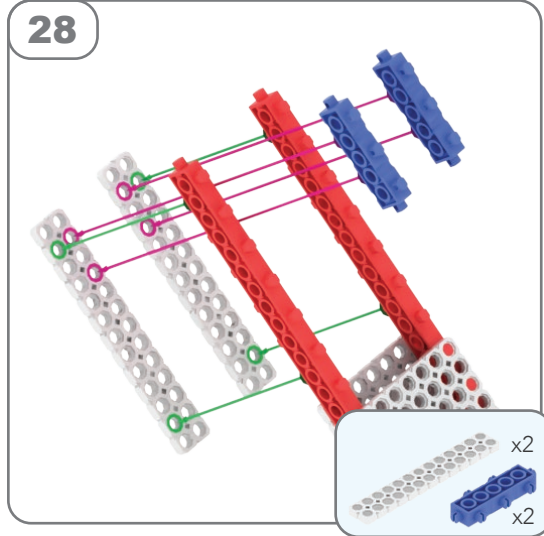

29

1:1

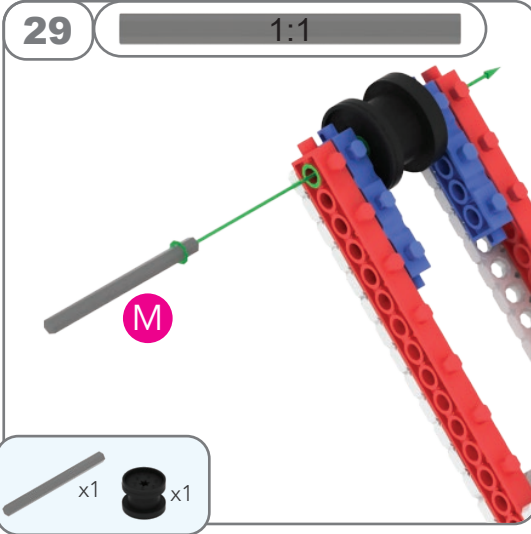

30

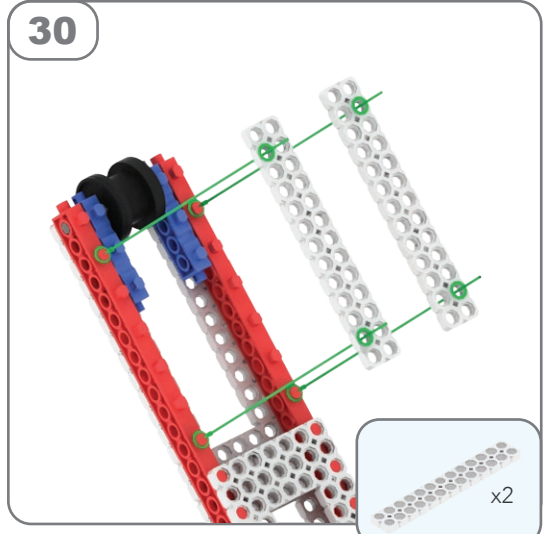

31

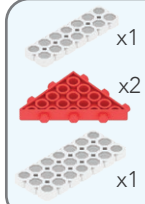
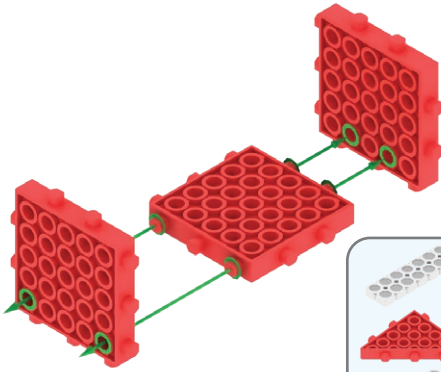

32

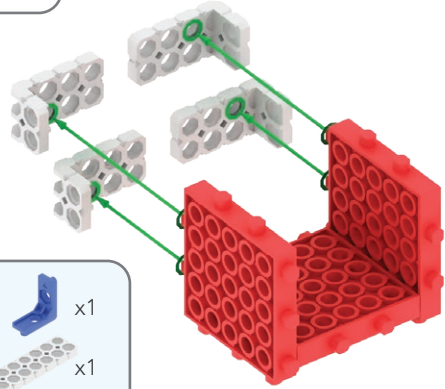

33

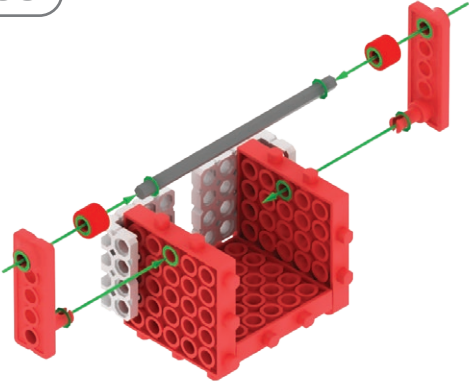

34

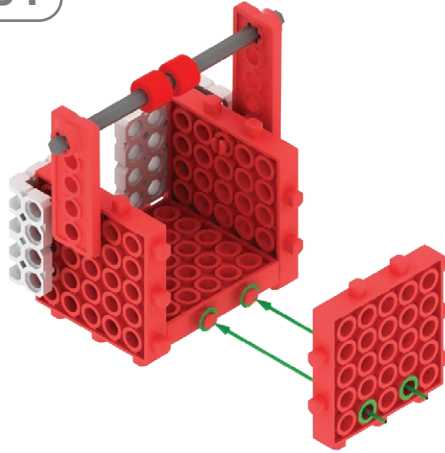

35

Treci cablul peste scripetele de sus și fă un nod la un capăt al coșului și de cealaltă parte la scripetele de jos

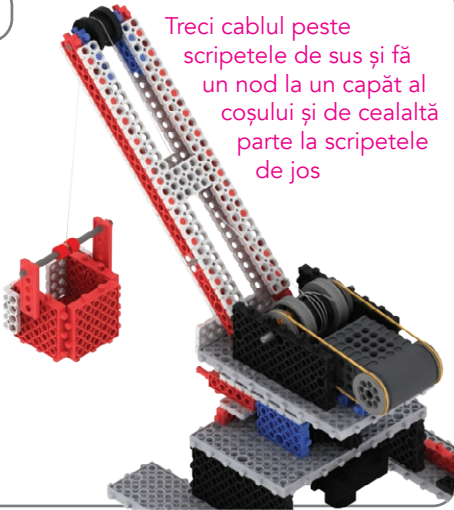

36

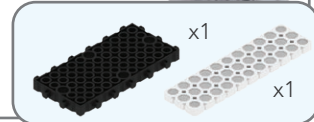
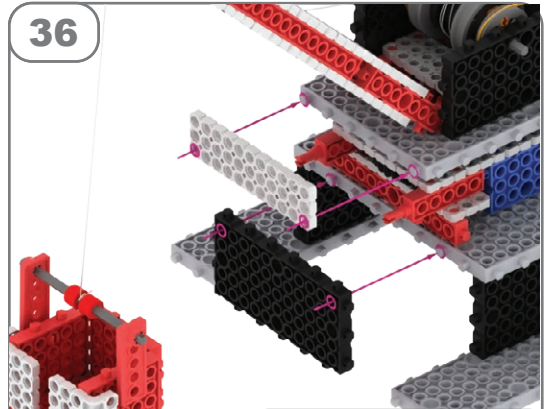

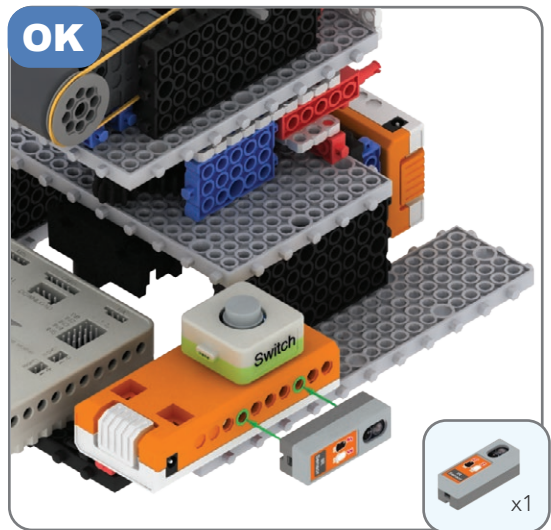
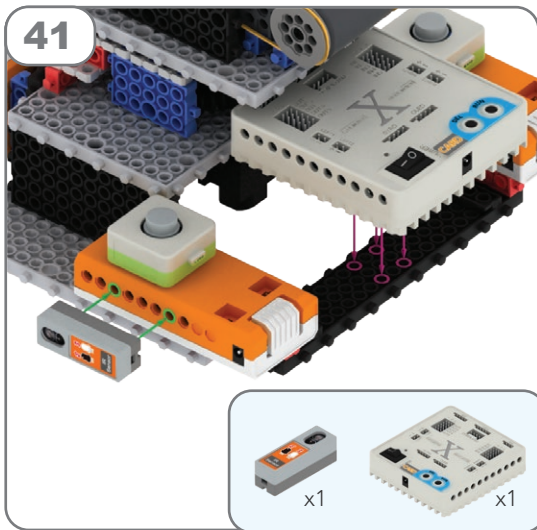
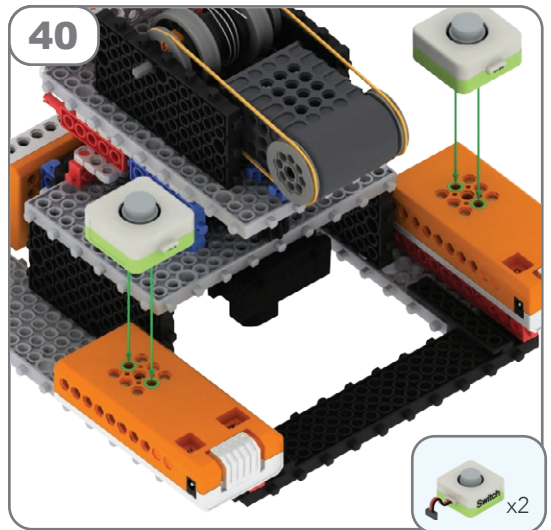
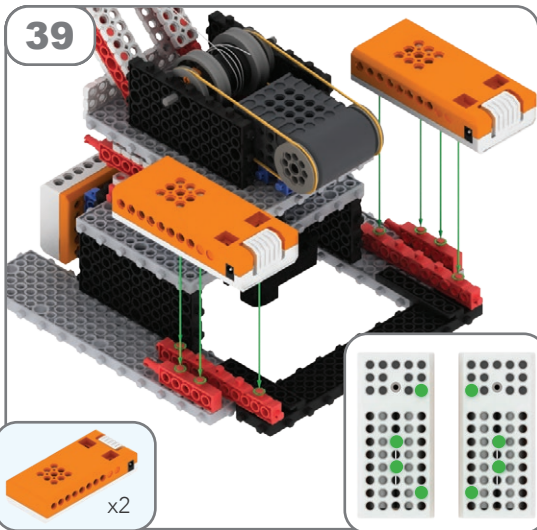
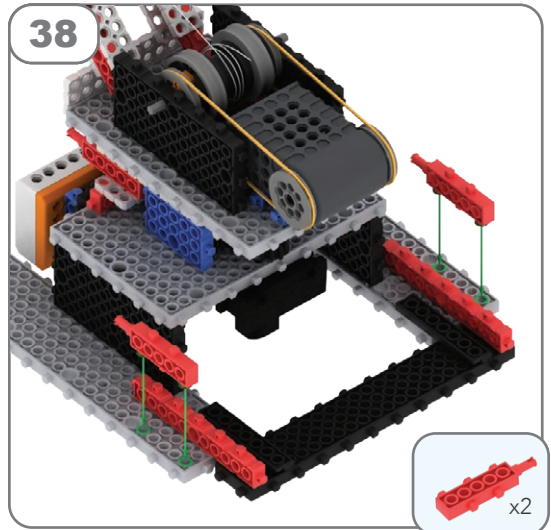
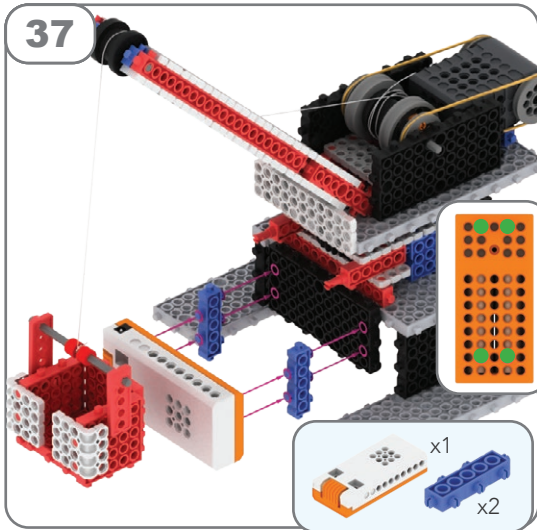

Cum se conectează?

Triunghiul ▲ trebuie să corespundă cu ▲ de pe conectorul de cablu al cititorului de carduri

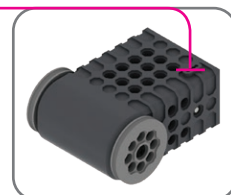
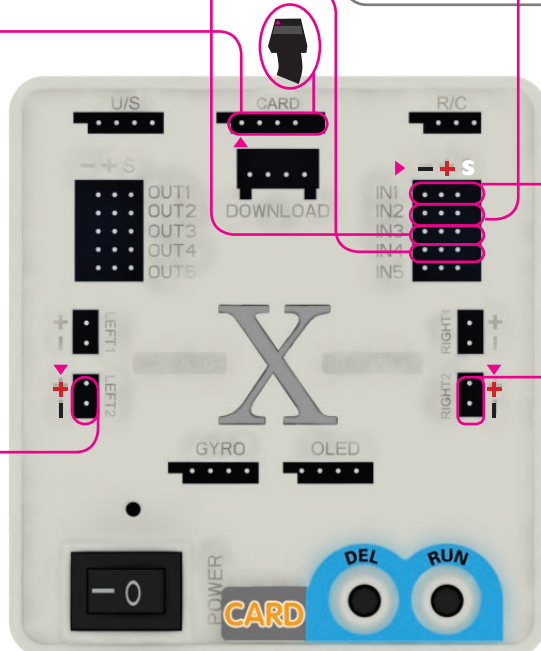
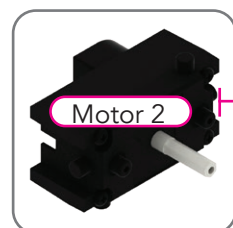
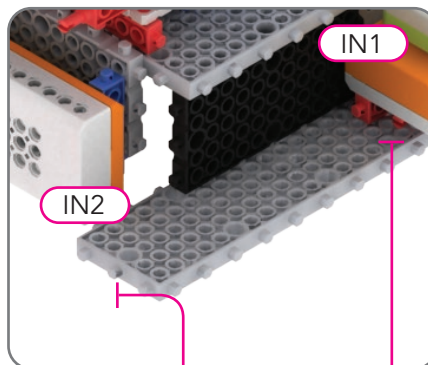
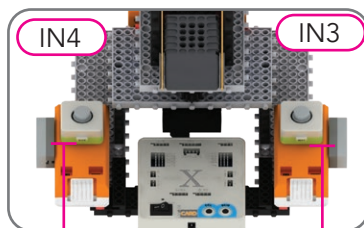

Pentru o descriere mai în detaliu, consultă secțiunea „Sfaturi pentru o bună asamblare” din revistă.

În practică



Consultă secțiunea „Învață să programezi” din revistă: acolo vei găsi o explicație mai detaliată și mai multe exemple de programare.

0

- 1.Cycle start (all time)
- 2.IF-IN1
- 3.Left motor 2 counterclockwise rotation
- 4.IF-IN2
- 5.Left motor 2 clockwise rotation
- 6.IF-IN3
- 7.Right motor 2 counterclockwise rotation
- 8.IF-IN4
- 9.Right motor 2 clockwise rotation
- 10.IF-NOT
- 11.Stop
- 12.Cycle end



IF-IN1



IF-IN2



IF-IN3



IF-IN4

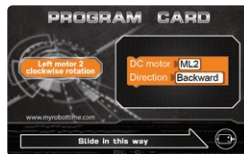

Left motor 2
counterclockwise rotation

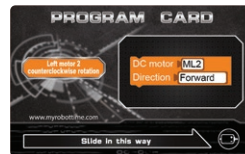

Left motor 2
counterclockwise rotation

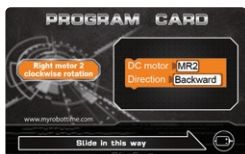

Right motor 2
clockwise rotation



Right motor 2
counterclockwise rotation



IF-NOT



Cycle start
(all time)



Cycle end



Stop