

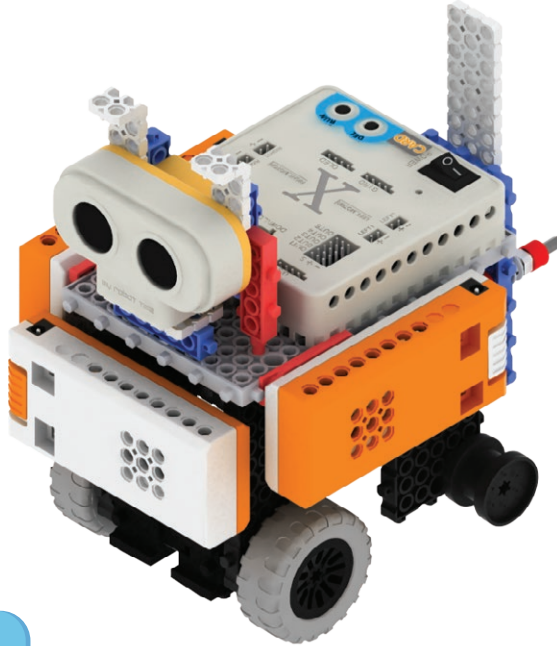

33 Robot câine

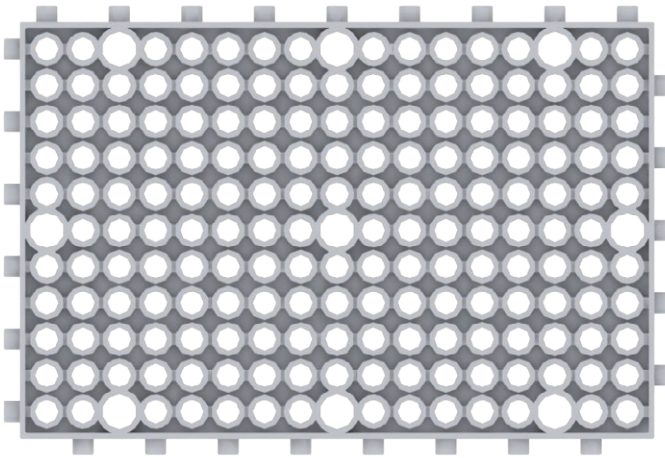

Piese



Bloc 11x17 (1)



Adaptor L 2x4 (2)



Bloc N 1x7 (1)



Bloc N 3x9 (3)



Bloc N 3x5 (1)



Bloc N 1x5 (1)

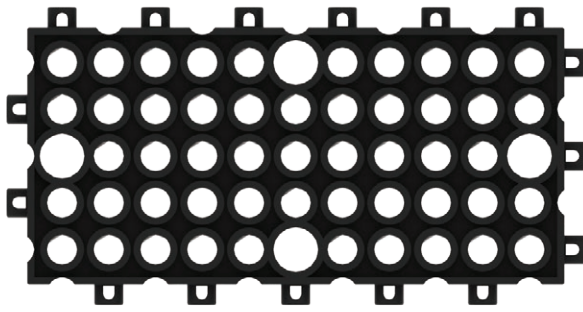

Bloc 5x11 (4)

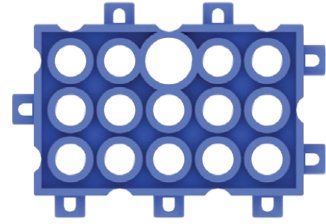

Bloc 3x5 (1)

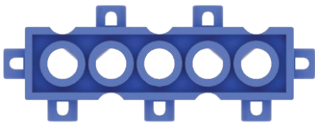

Bloc 1x5 (6)



Roată de direcție (2)



Adaptor L (2)

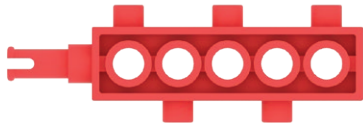

Bloc cu ax (2)

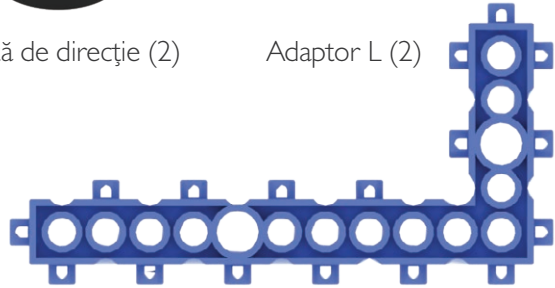

Bloc de 90° (1)



Roată M (2)



Jantă 2 (1)



Motor 2 (2)



Conector de ax (2)



Cauciuc roșu de ax (2)



Piuliță (4)



Ax S (1)



Nit clasic (7)



Nit S (1)



Nit L (3)

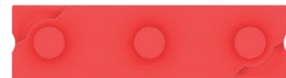

Bloc de îmbinare 1 (2)



Motor 1 (1)



Senzor de ultrasunete (1)



Cablu de conectare (3)

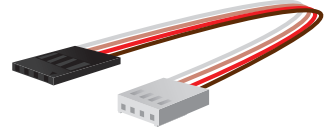

Prelungitor (1)



Acumulator 1 (1)

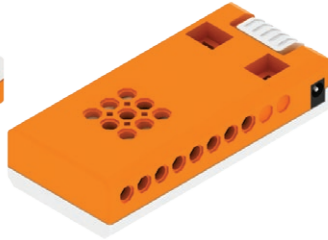

Acumulator 2 (2)

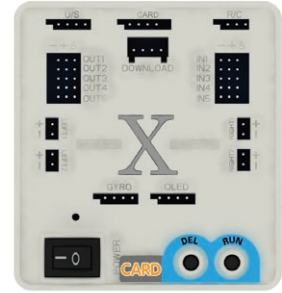

Placă de bază MRT Card(1)

01

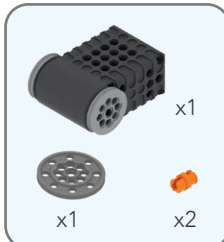
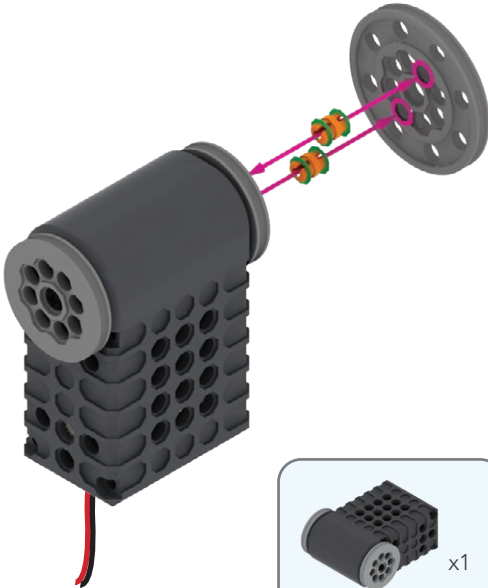

02

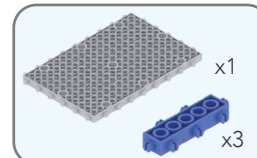
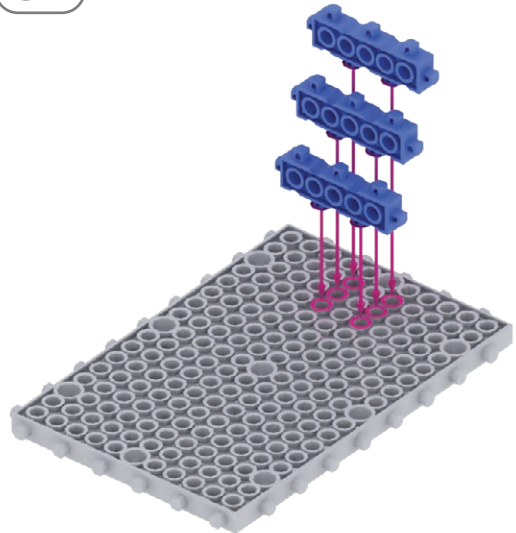

03

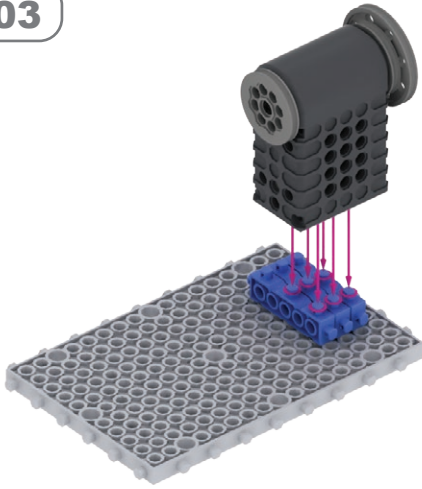

04

Notă: triunghiul roșu ▲ indică poziția.

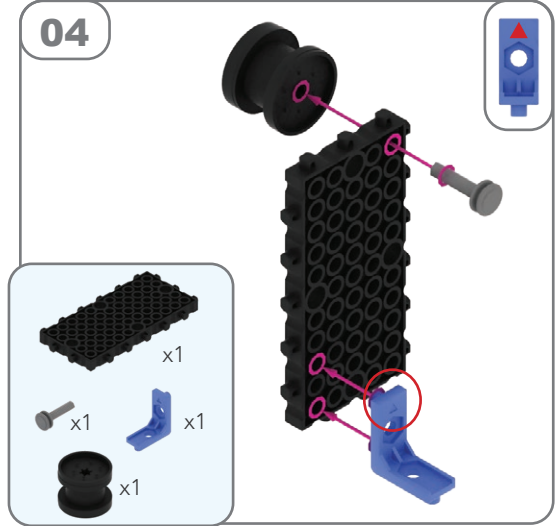

05

Notă: triunghiul roșu ▲ indică poziția.

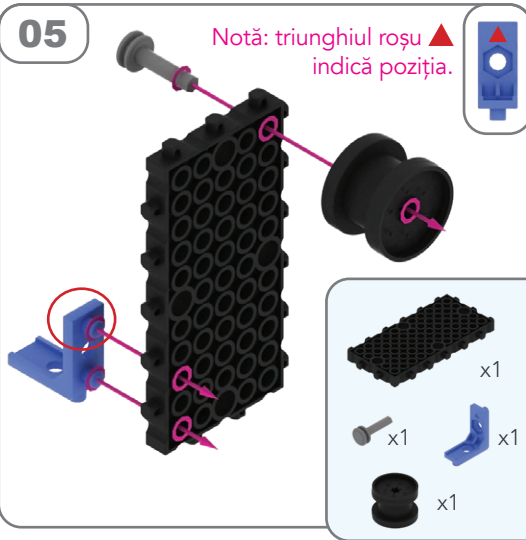

06

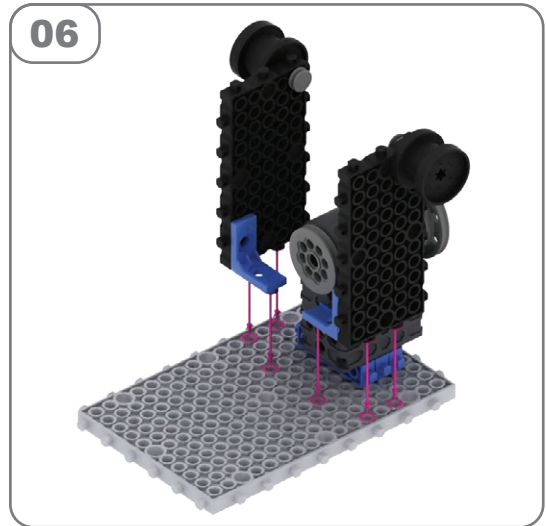

07

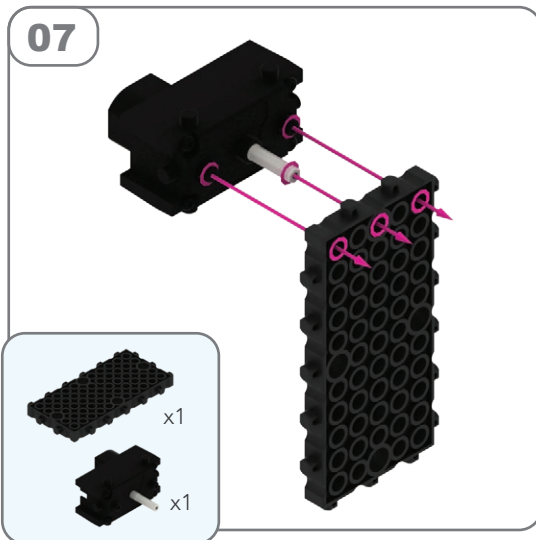

08

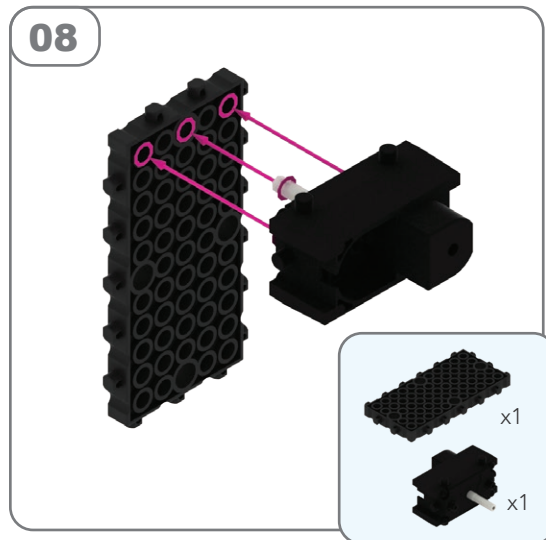

15

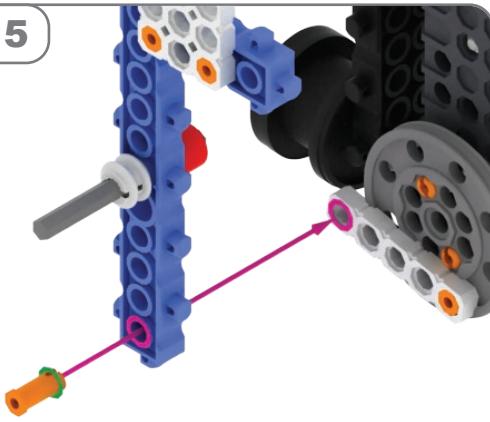

16

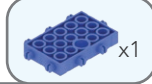
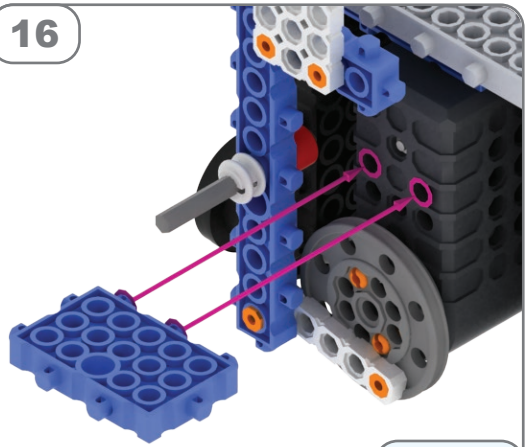

17

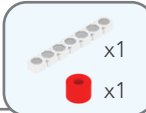
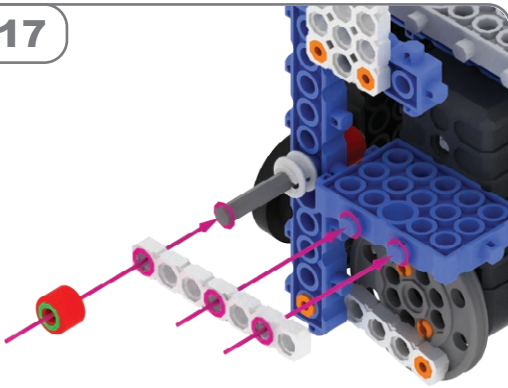

18

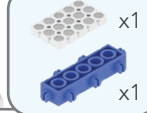
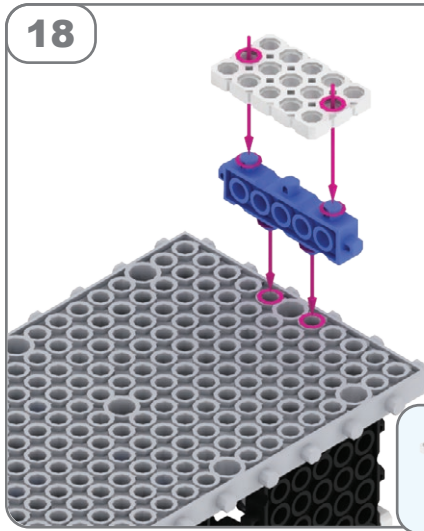

19



20

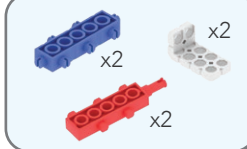
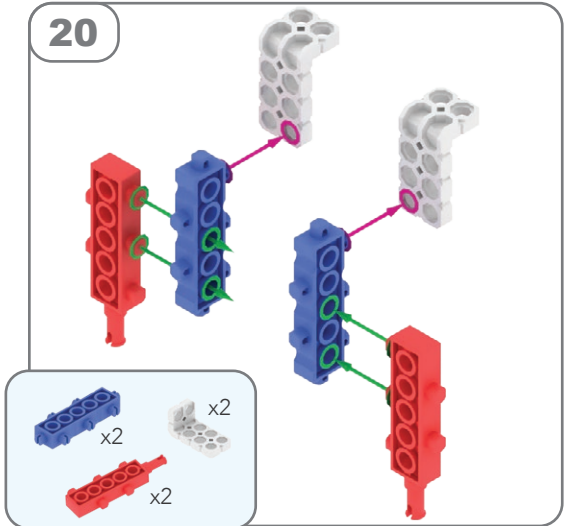

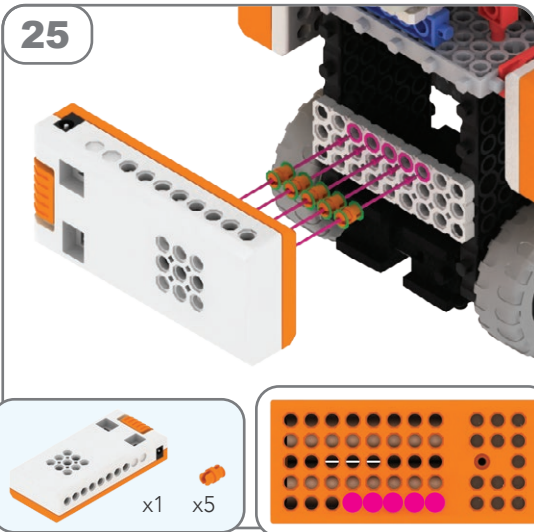
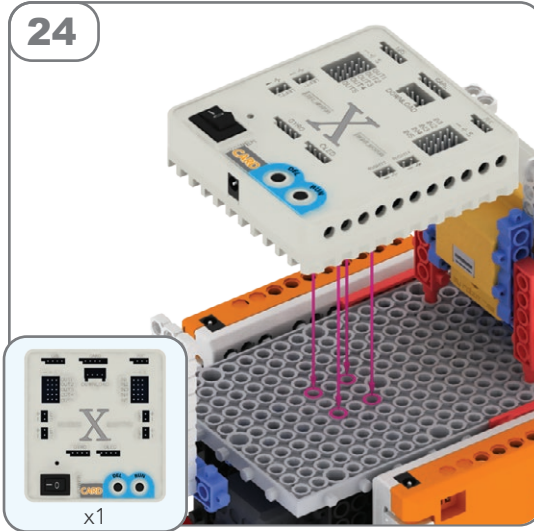
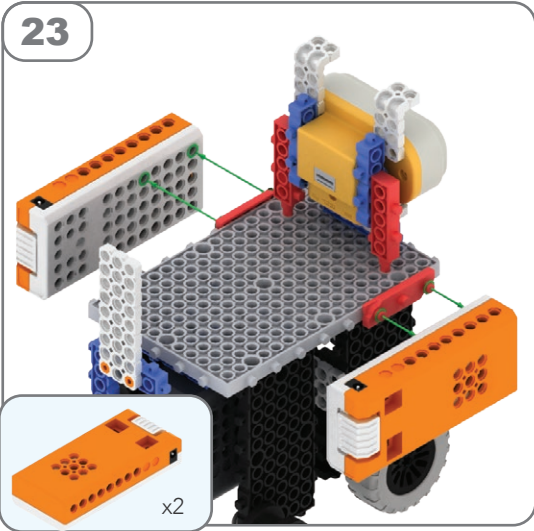
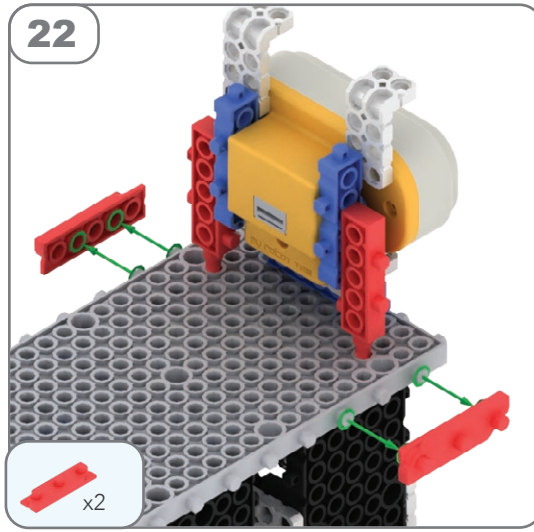
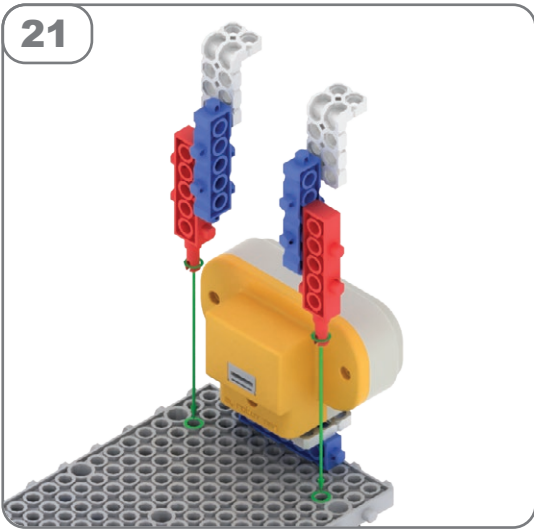

Cum se conectează?

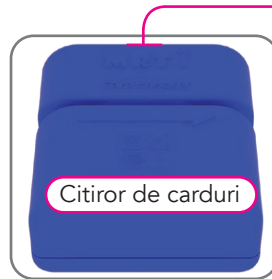

Triunghiul ▲ trebuie să corespundă cu ▲ de pe conectorul cablului de pe cititorul de carduri

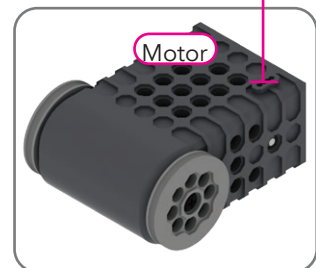
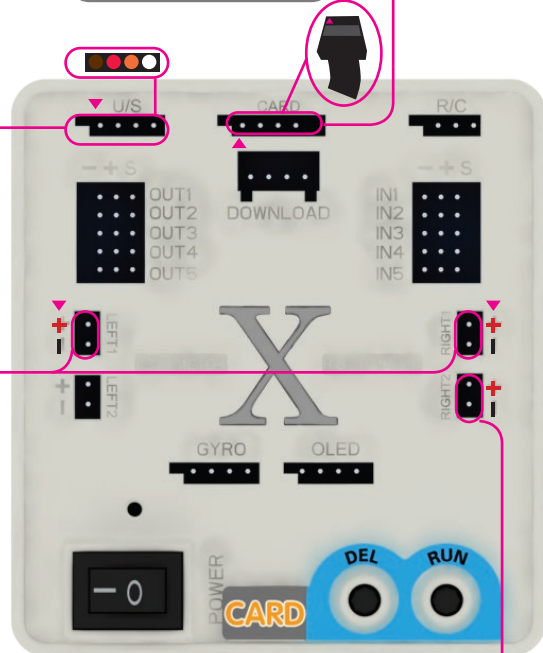
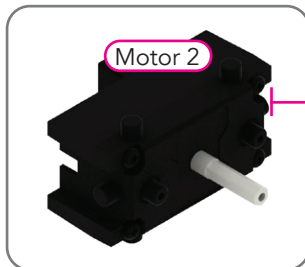

În practică



Detect distance
2cm-10cm



Detect distance
10cm-50cm



Delay 1 sec



Detect distance
50cm-100cm



Stop



Forward



Right motor 2
counterclockwise rotation



Cycle start
(all time)



Cycle end

Programare:

1. Cycle start (all time)
2. Detect distance 50cm-100cm
3. Stop
4. Detect distance 10cm-50cm
5. Forward
6. Delay 1 sec
7. Stop
8. Detect distance 2cm-10cm
9. Right motor 2 counterclockwise rotation
10. Cycle end