

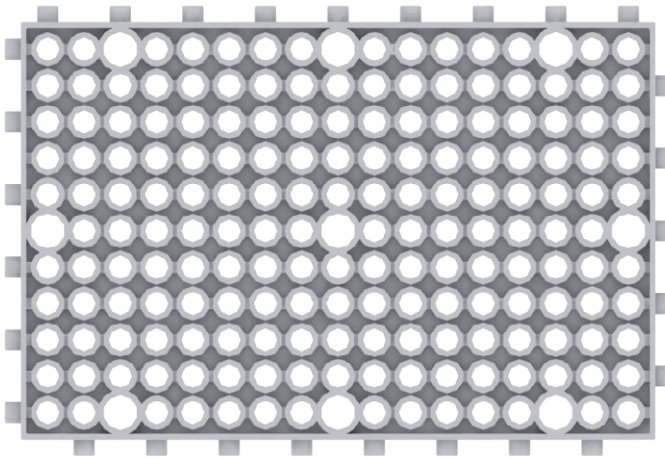

## 35 Robot multifuncțional



### Piese



Bloc 11x17 (2)

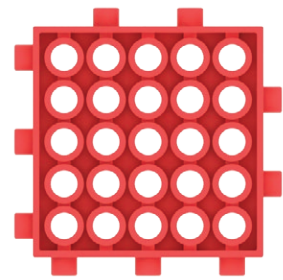

Bloc 5x5 (2)

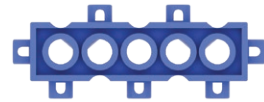

Bloc 1x5 (6)



Bloc N 3x5 (1)



Piuliță (4)

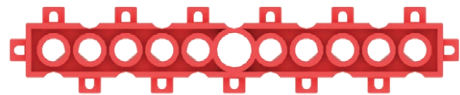

Bloc 1x11 (2)

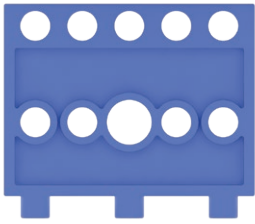

Suport de motor (2)

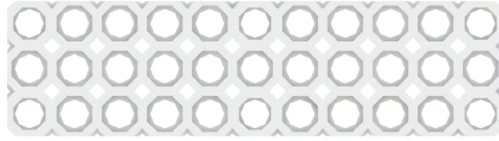

Bloc N 3x11 (1)

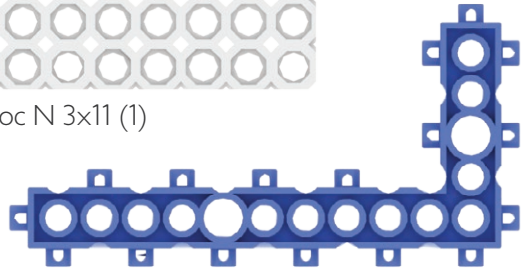

Bloc de 90° (1)

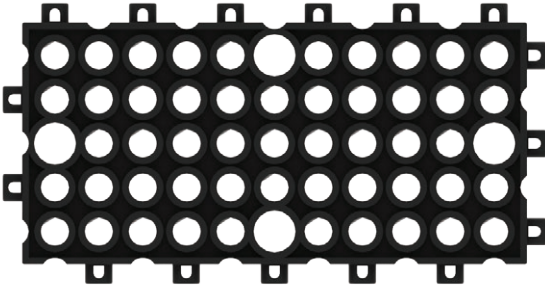

Bloc 5x11(2)

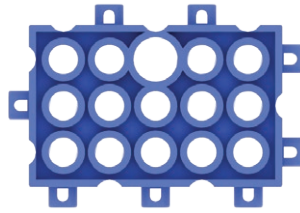

Bloc 3x5 (2)

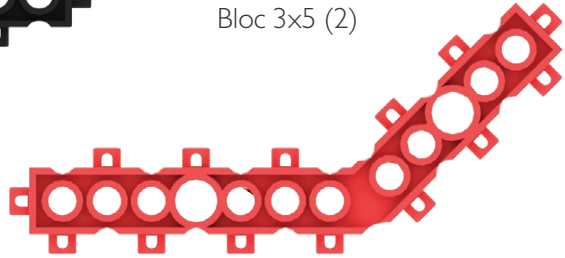

Bloc de 45° (6)



Roată M (2)

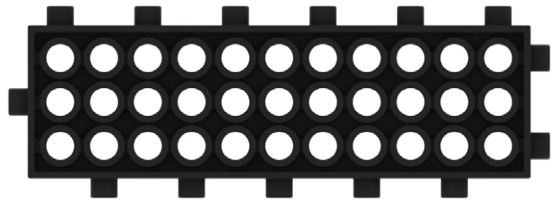

Bloc 3x11 (1)



Motor 2 (2)

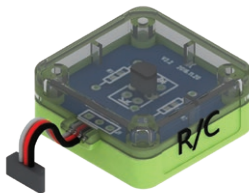

Senzor R/C (1)



Senzor cu infraroșu (2)

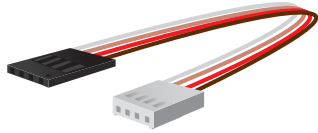

Prelungitor (1)



Acumulator 1 (1)



Cablu de conectare (3)



Senzor de ultrasunete (1)



Acumulator 2 (2)



Placă de bază MRT Card (1)

01

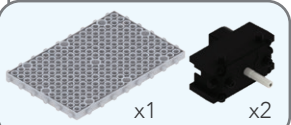
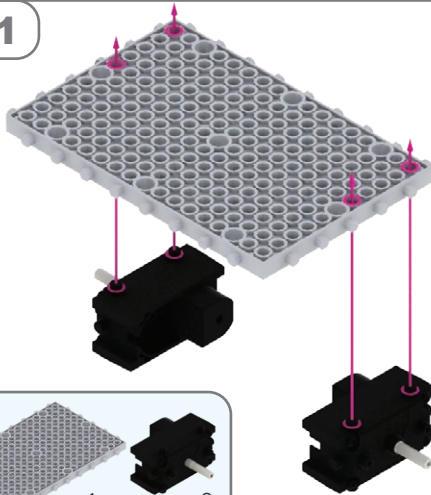

02

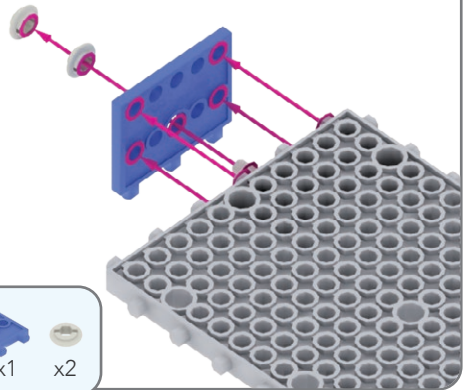

03

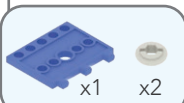
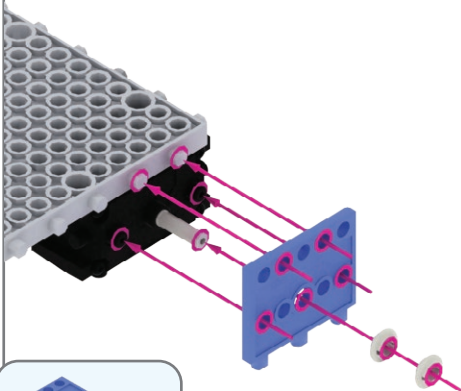

04

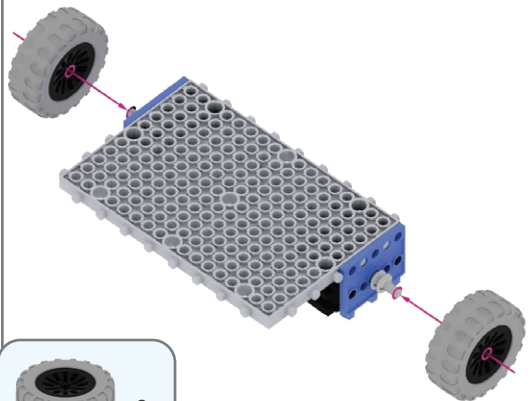

05

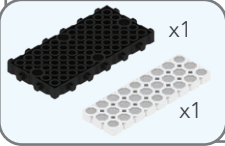
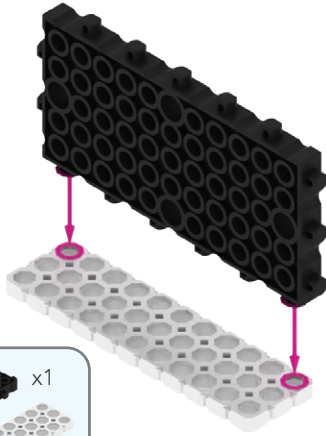

06

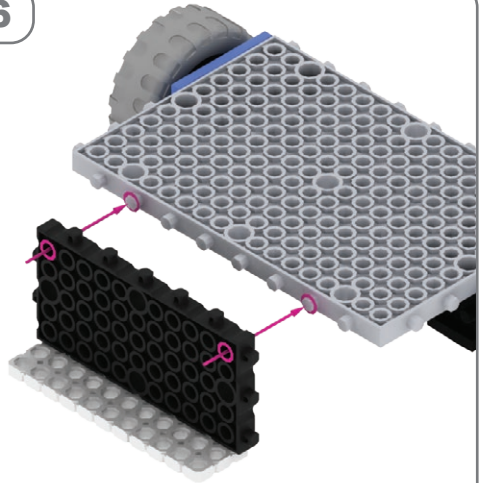

07

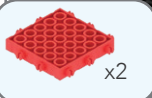
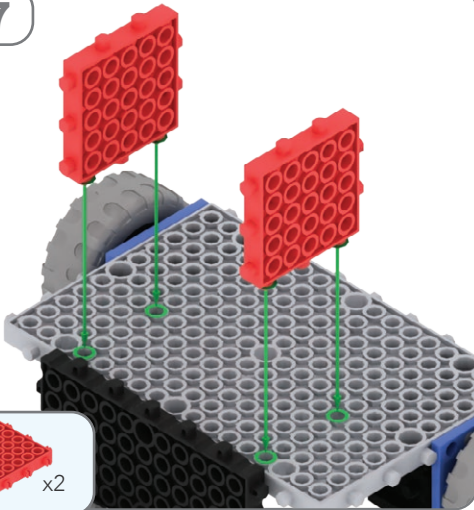

08

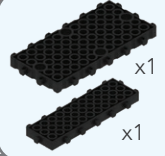
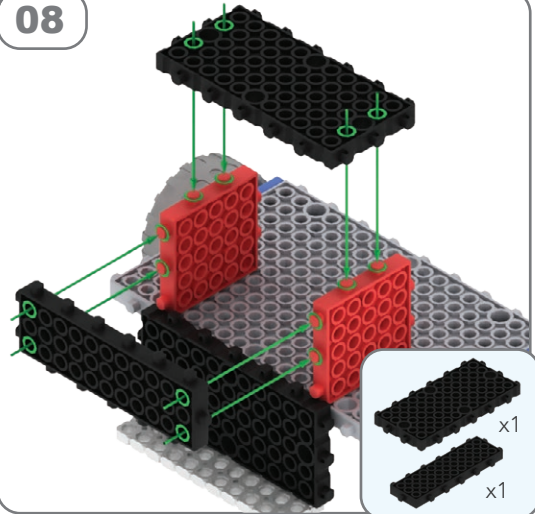

09

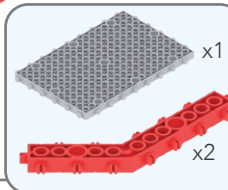
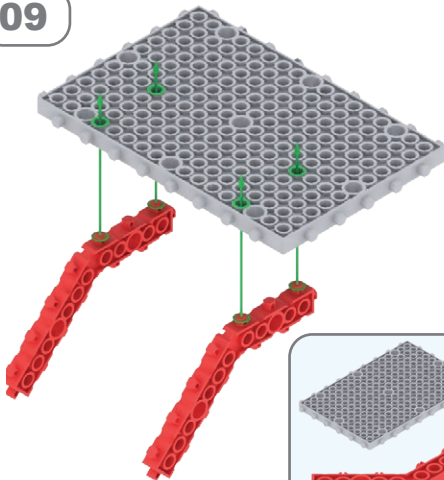

10

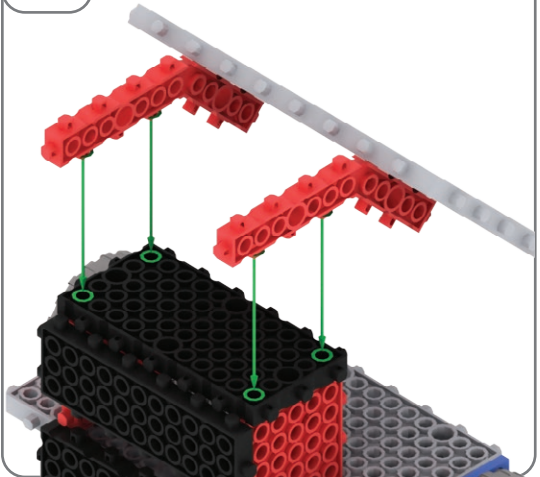

11

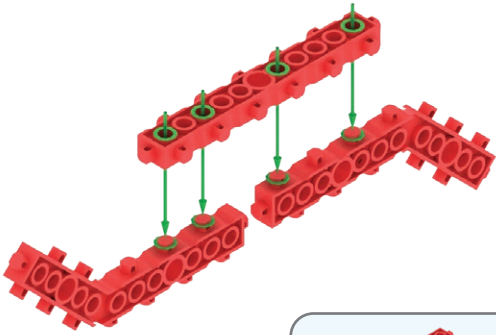

X2

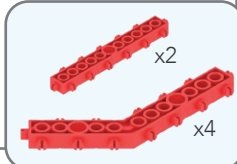

12

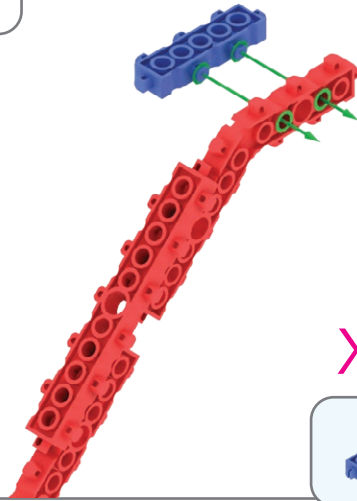

X2

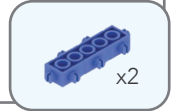

13

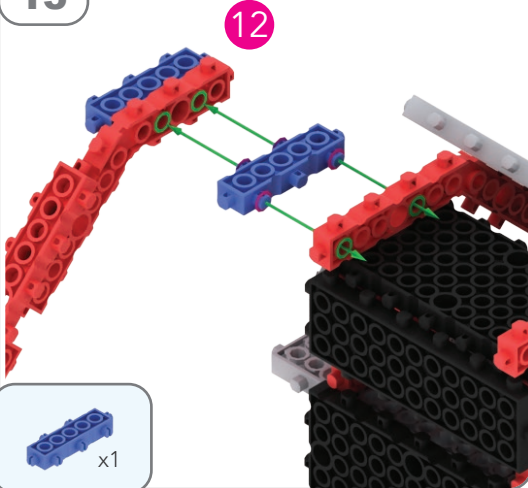

14

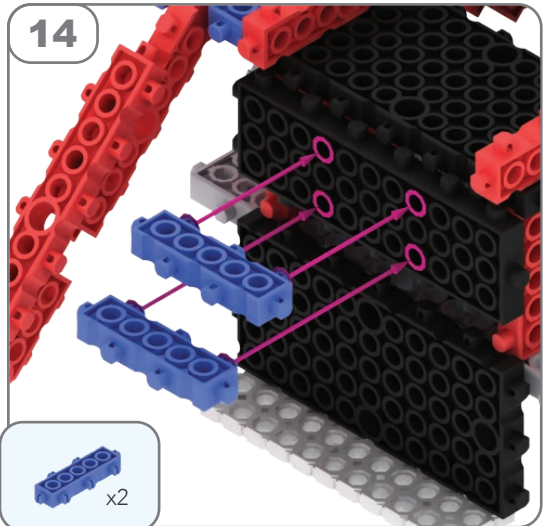

15

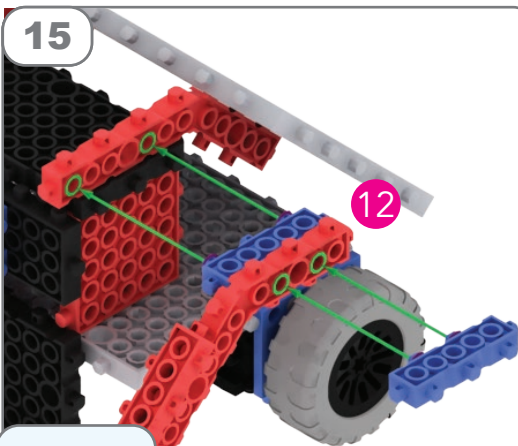

16

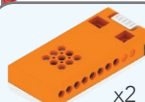
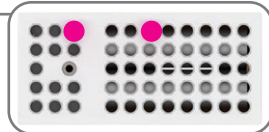
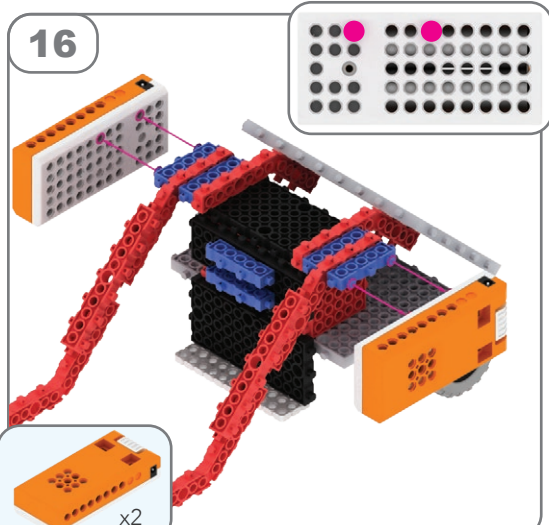

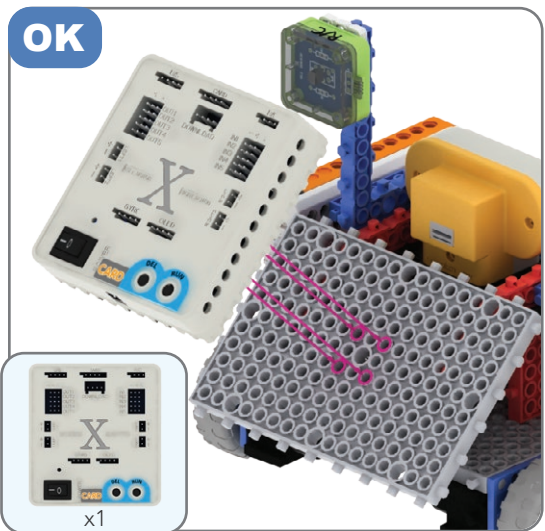
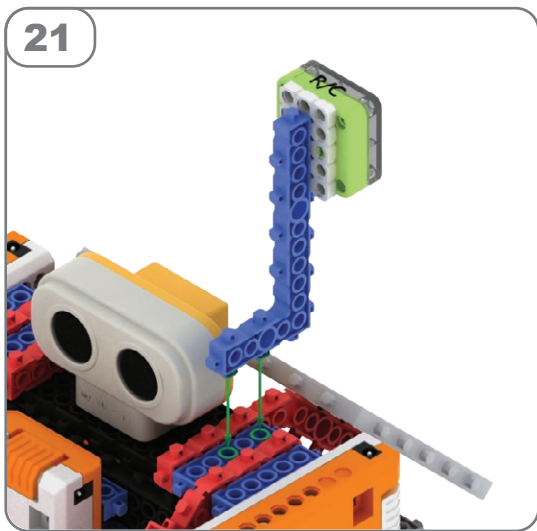
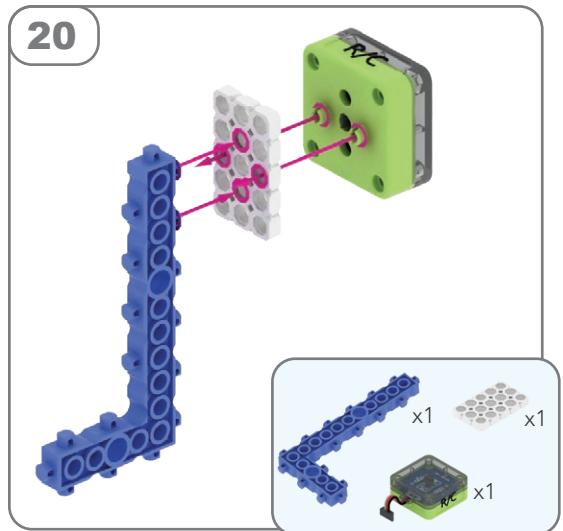
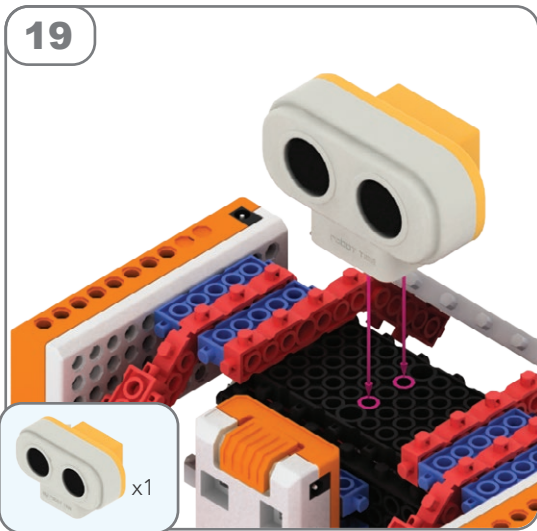
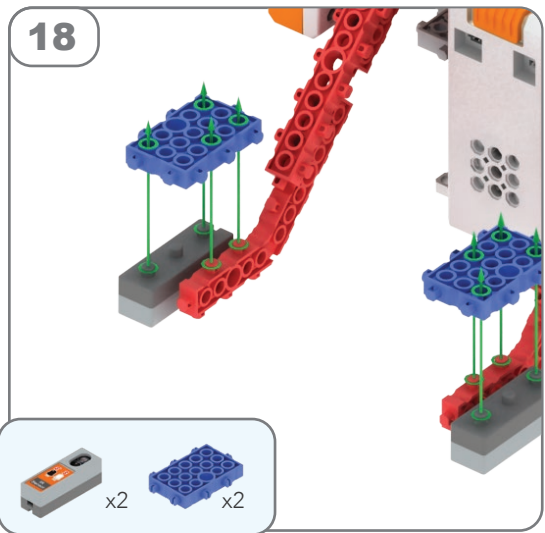
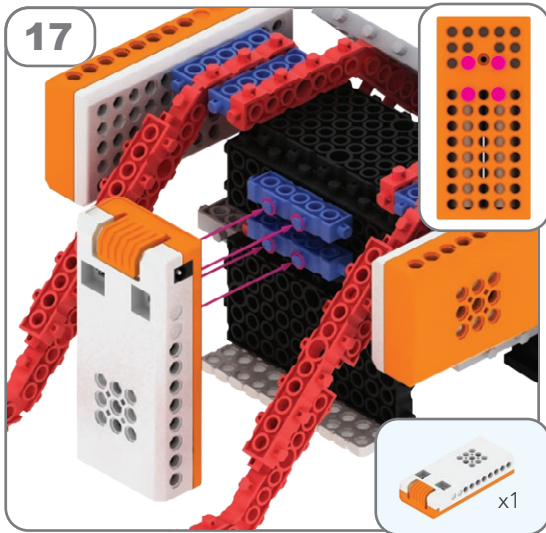

## Cum se conectează?

Cititor de carduri

Triunghiul ▲  
trebuie să  
corespondă  
cu ▲ de pe  
conectorul  
cablului de  
pe cititorul de  
carduri

R/C

Ultrasunete

Motor 2

Acumulatori

IR

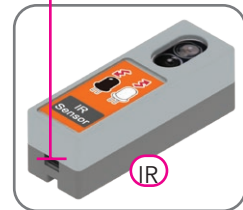
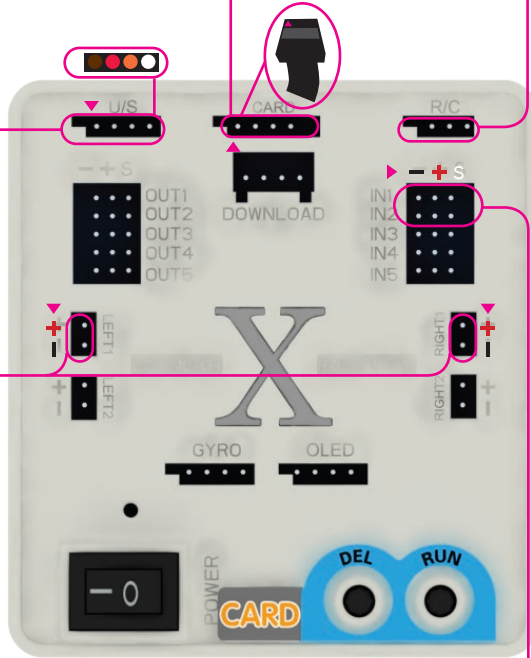
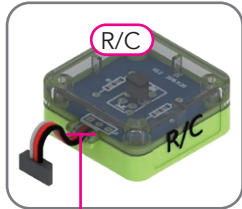
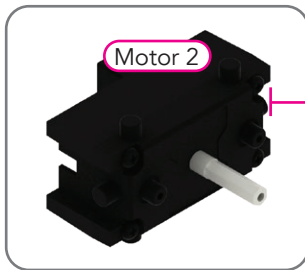

# În practică

